

PCB LAYOUT TOP VIEW
TOLERANCES:±0.05

SPECIFICATIONS:

1. ELECTRICAL CHARACTERISTICS:
 - 1-1. RATING:
 - 1-2. CONTACT RESISTANCE: 30mΩ MAX.(INITIAL)
 - 1-3. DIELECTRIC WITHSTANDING VOLTAGE: 500V AC FOR ONE MINUTE
 - 1-4. INSULATION RESISTANCE: 100MΩ MIN. MEASURED BY 500V DC
2. MECHANICAL CHARACTERISTICS:
 - 2-1. INSERTION FORCE : 0.3~3.0 KGF
 - 2-2. WITHDRAWAL FORCE : 0.3~3.0 KGF
3. LIFE TEST: 5,000 CYCLES MIN.
4. FOR REFLOW SOLDERING LEAD-FREE PROCESS.
5. REPRESENT CRITICAL DIMENSIONS.

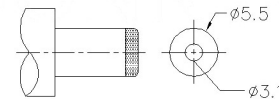
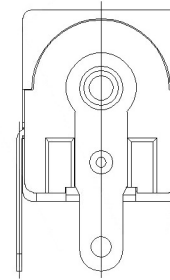
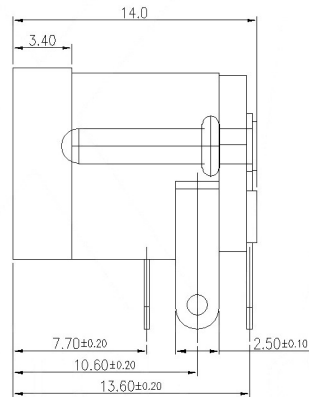
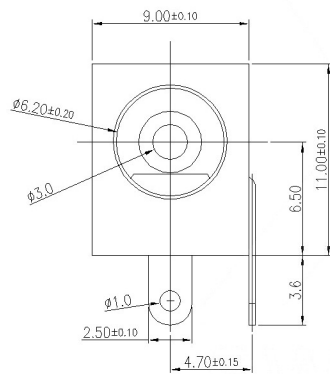

MATING PLUG
Jack Insertion Depth: 9.0 mm

SCHEMATIC	
Model	DC-005
Center Pin	2.0
	2.5
	3.0

	MATERIAL	PLATING
center pin	Brass	silver
terminal 1	Brass	silver
terminal 2	Phosphor Bronze	silver
terminal 3	Brass	silver
plastic	Pbt	

MARK	DESCRIPTION	DATE	REVISED	APPROVED	ANGLAR	±5°	DSND	DATE	SCALE: N/A	MODEL TYPE:			
△ X					X.X	±0.2mm	DWN	DATE	VIEW:	DC POWER JACK			
△ X					X.XX	±0.1mm	CHKD	DATE	UNIT: mm	PART NO.:			
△ X					X.XXX	±0.05mm	APPD	DATE	SIZE: A4	DWG NO.:			
							UNSPECIFIED TOLERANCES	KOSOD TECHNOLOGY CO., LTD			DC-005-5A-3.0		
www.bodongkaiguan.net www.ksdkg.com											WEIGHT	SHEET	REVISION
											1.0g	1/1	A0