

- SPECIFICATIONS:
- ELECTRICAL CHARACTERISTICS:
 - RATING:
 - CONTACT RESISTANCE: 30mΩ MAX.(INITIAL)
 - DIELECTRIC WITHSTANDING VOLTAGE: 500V AC FOR ONE MINUTE
 - INSULATION RESISTANCE: 100MΩ MIN. MEASURED BY 500V DC
 - MECHANICAL CHARACTERISTICS:
 - INSERTION FORCE : 0.3~3.0 KGF
 - WITHDRAWAL FORCE : 0.3~3.0 KGF
 - LIFE TEST: 5,000 CYCLES MIN.
 - FOR REFLOW SOLDERING LEAD-FREE PROCESS.
 - REPRESENT CRITICAL DIMENSIONS.

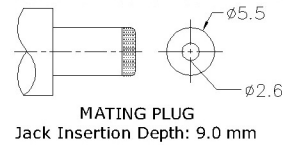
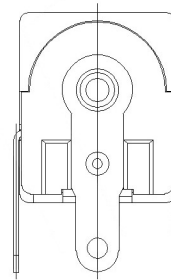
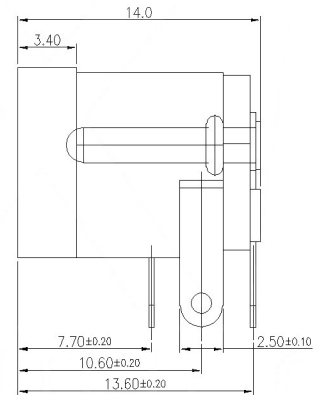
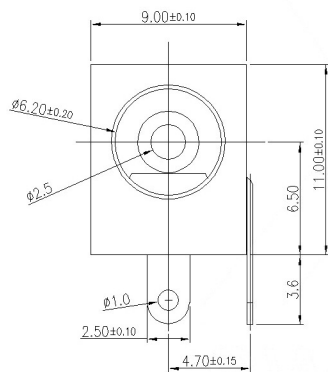

SCHEMATIC	
Model	DC-005
Center Pin	2.0
	2.5
	3.0

	MATERIAL	PLATING
center pin	Brass	silver
terminal 1	Brass	silver
terminal 2	Phosphor Bronze	silver
terminal 3	Brass	silver
plastic	Pbt	

MARK	DESCRIPTION	DATE	REVISED	APPROVED	ANGLAR	±5°	DSND	DATE	SCALE: N/A	MODEL TYPE: DC POWER JACK		
△X					X.X	±0.2mm	DWN	DATE	VIEW:	PART NO.:		
△X					X.XX	±0.1mm	CHKD	DATE	UNIT: mm	DWG NO.:		
△X					X.XXX	±0.05mm	APPD	DATE	SIZE: A4	DC-005-5A-2.5		
UNSPECIFIED TOLERANCES							Kosod Technology Co., Ltd.			WEIGHT	SHEET	REVISION
www.bodongkaiguan.net		www.ksdkg.com								1.0g	1/1	A0