

CUSTOMER DRAWING

REV.	DESCRIPTION	APPROVED BY	DATE	ECN NO.
A	RELEASE	Emily Suen	23/08/12'	
B				
C				

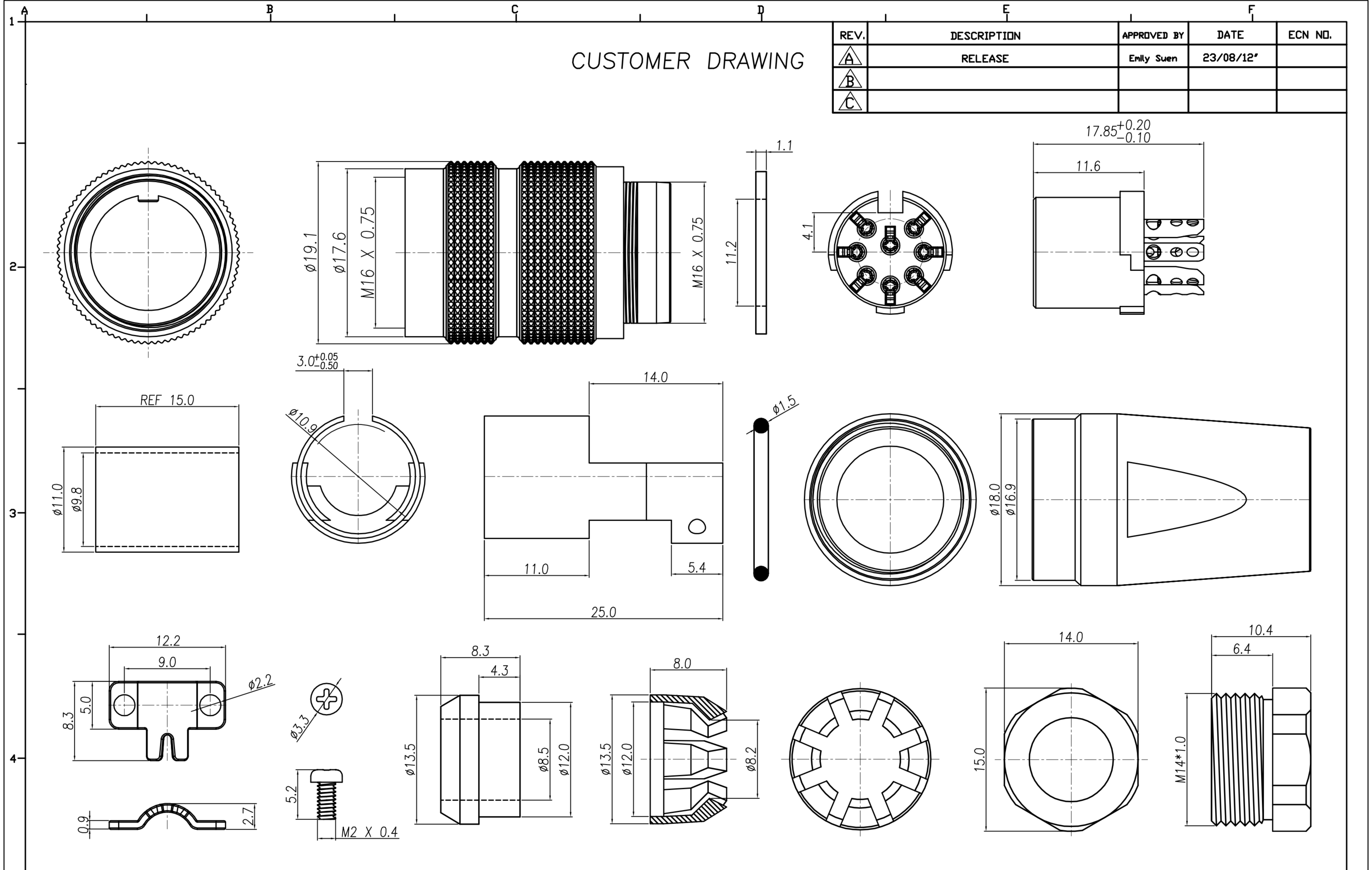

DRAWN	Mark Kao	APP'D	Ku Chou	UNIT	mm	TOLERANCE		TITLE	WP DIN (F) Assembly type			SHEET	
CHK'D	Emily Suen			SCALE	1:1	.x ±0.20 .xx ±0.10 .xxx ±0.05 .xxxx ±0.03 ANGULA ±1°			PART NO.	SEE TABLE A	DWG NO.	QC5932	3 3
													VERSION A

广东科斯达电子科技有限公司
 GUANG DONG KE SI DA ELECTRONIC TECHNOLOGY CO., LTD.

CUSTOMER DRAWING

REV.	DESCRIPTION	APPROVED BY	DATE	ECN NO.
△A	RELEASE	Emily Suen	23/08/12'	
△B	額定電流	Ku	26/06/18'	
△C	接線位置	LED	21/01/19'	ECN-19002

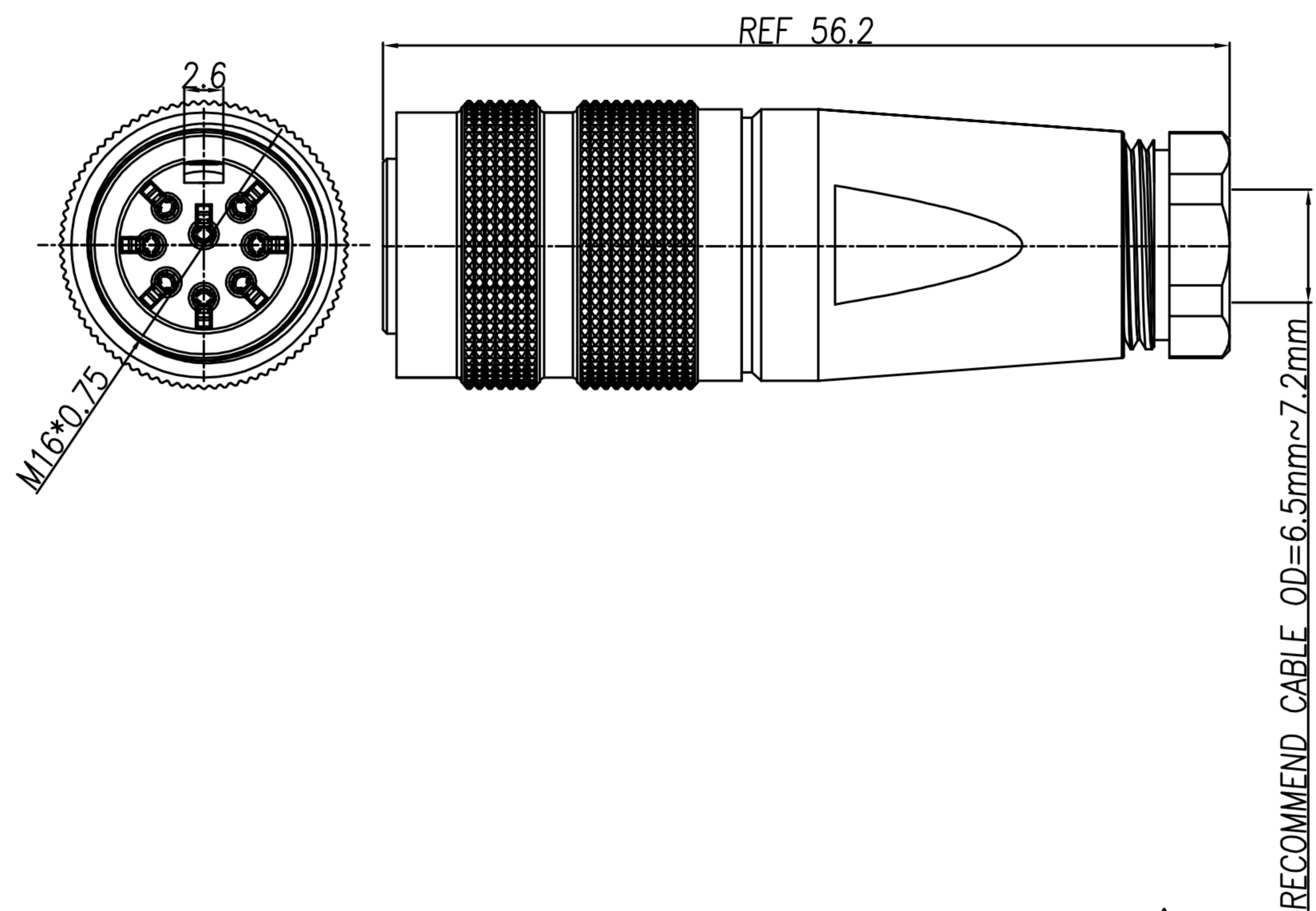

- MATERIAL :
 - 1-1. HOUSING : NYLON UL94V-0 ; COLOR : BLACK
 - 1-2. CONTACT : PHOSPHOR BRONZE
 - 1-3. MAIN BODY : ZINC ALLOY
 - 1-4. LOCK SHELL : BRASS
 - 1-5. SPRING : STAINLESS
 - 1-6. ISOLATION : PVC
 - 1-7. CLAMPS : ZINC ALLOY
 - 1-8. CLAMPS BODY : ZINC ALLOY
 - 1-9. SCREW : SPCC
 - 1-10. BACK BODY : BRASS
 - 1-11. O-RING 1 : SILICONE ; COLOR : RED
 - 1-12. GLAND : SILICONE COLOR : BLACK
 - 1-13. GLAND CAGE : POM ; COLOR : WHITE
 - 1-14. GLAND NUT : ALUMINUM ALLOY
 - 1-15. O-RING 2 : SILICONE ; COLOR : BLACK
- FINISH :
 - 2-1. CONTACT : CONTACT AREA : GOLD FLASH PLATING
SOLDER AREA : TIN
UNDER PLATE : NICKEL
 - 2-2. MAIN BODY : NICKEL PLATED
 - 2-3. LOCK SHELL : NICKEL PLATED
 - 2-4. CLAMPS : NICKEL PLATED
 - 2-5. CLAMPS BODY : NICKEL PLATED
 - 2-6. SCREW : NICKEL PLATED
 - 2-7. BACK BODY : NICKEL PLATED
 - 2-8. GLAND NUT : SATING NICKEL PLATED
- ELECTRICAL SPECIFICATION :
 - △3-1. Rated current : 5A
 - 3-2. Rated Voltage : 250V
 - 3-3. Water proof : IP67
- Environmental :
 - 4-1. Operation Temperature : -20℃~85℃

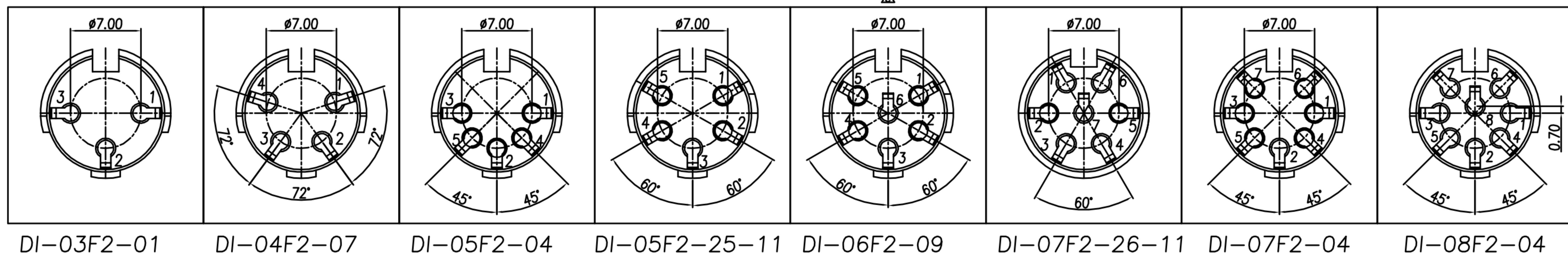

DRAWN	Mark Kao	APP'D	Ku Chou	UNIT	mm	TOLERANCE				TITLE	WP M16 DIN (F) Assembly type			SHEET	1/3
CHK'D	Emily Suen			SCALE	1:1	.x ±0.20 .xx ±0.10 .xxx ±0.05 .xxxx ±0.03 ANGULA ±1°				PART NO.	SEE TABLE A	DWG NO.	QC5932	VERSION	C

CUSTOMER DRAWING

REV.	DESCRIPTION	APPROVED BY	DATE	ECN NO.
A	RELEASE	Emily Suen	23/08/12'	
B				
C				

ASSEMBLY INSTRUCTION

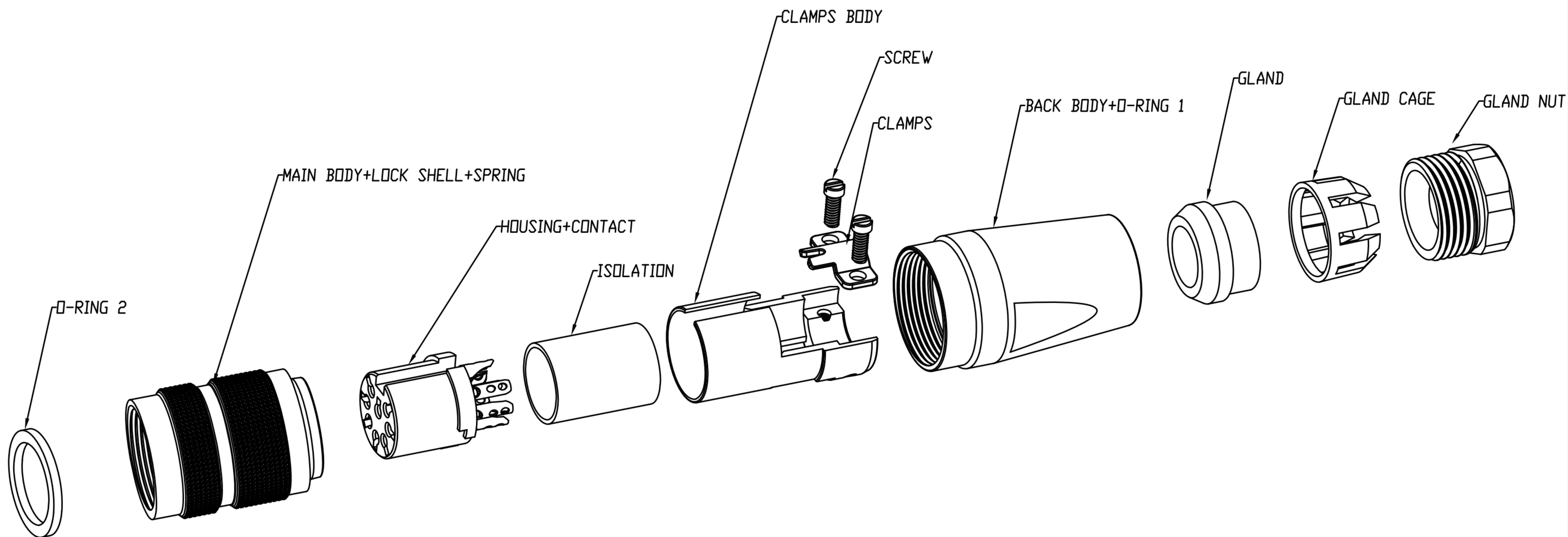

DRAWN	Mark Kao	APP'D	Ku Chou	UNIT	mm	TOLERANCE		广东科斯达电子科技有限公司 GUANG DONG KE SI DA ELECTRONIC TECHNOLOGY CO., LTD.	TITLE	WP DIN (F) Assembly type			SHEET
CHK'D	Emily Suen			SCALE	1:1	.x ±0.20 .xx ±0.10 .xxx ±0.05 .xxxx ±0.03 ANGULA ±1°			PART NO.	SEE TABLE A	DWG NO.	QC5932	VERSION