

SPRING RETURN

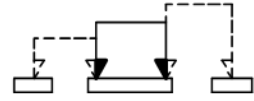

NON-SHORTING
SCHEMATIC

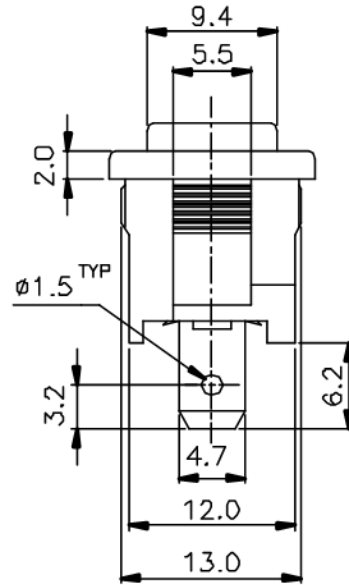
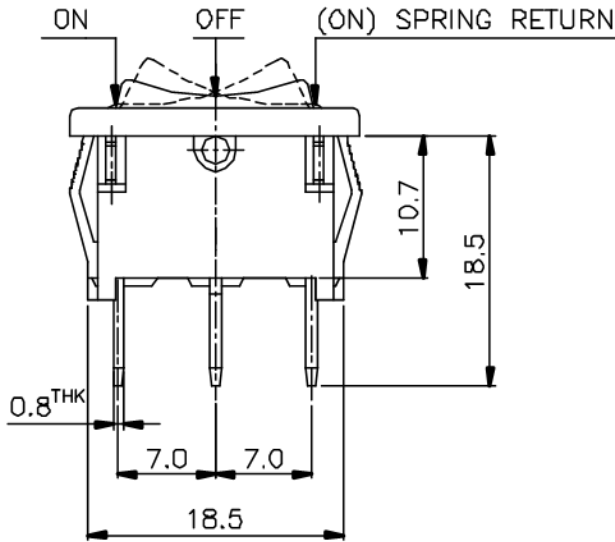
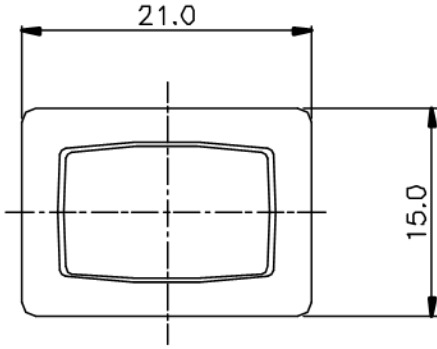

Panel Cut-out Dimensions

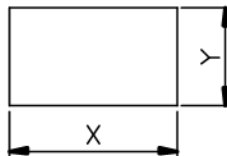

Rating : UL: U11  11A 125VAC
5.5A 250VAC

Remark: Marked With L11 Logo 

| Panel Thickness (mm/inch) | DIM X ⁺⁰ _{-0.1} (mm/inch) | DIM Y ^{±0.1} (mm/inch) |
|------------------------------|--------------------------------------------------|------------------------------------|
| 0.5~1.3 (.02~.05) | 19.4 (.764) | 13.1 (.516) |
| 1.2~2.0 (.05~.08) | 19.7 (.775) | |
| 2.0~3.0 (.08~.12) | 20.0 (.787) | |

| ISSUED | SPECIFICATION (INITIAL) | TITLE: ROCKER SWITCH 1P3T | | |
|--------|-----------------------------------------------------------------------------------------------------------------------------------------------------------------|------------------------------|-------|--|
| | RATING: AC 125V 11A ; 250V 5.5A | MODEL NO: U11WR-13N09-R1(00) | | |
| | CONTACT RESISTANCE: MAX. 30mΩ | UNIT: mm | DWN | |
| | INSULATION RESISTANCE: 500MΩ at 500V DC | SCALE: 2 : 1 | CHK'D | |
| | WITHSTAND VOLTAGE: AC 1000V for 1 min | TOLERANCE: ±0.2 | APPD. | |
| | OPERATION FORCE: 500±300g | | | |
| | SWITCHING LIFE:10000 Cycles(6-10c/m loading) | | | |
| BY: |  广东科斯达电子科技有限公司 GUANG DONG KE SI DA ELECTRONIC TECHNOLOGY CO., LTD. | DRWG NO: | | |
| DATE: | | A00311-02 | | |