

SPECIFICATION:

1. Material
 - Housing Material: High temperature thermoplastic
 - Contact Terminal: High Grade Copper Alloy
 - Metallic Shell: Stainless Steel
 - Inner Ground Cover Shell: Stainless Steel
 - Mid Plate: Stainless Steel
2. Mechanical:
 - 2.1. Mating force: 5-20Nf;
 - 2.2. Unmating force: Initial: 8-20Nf; Final: 6-20Nf;
 - 2.3. Durability: 5000 Cycles;
3. Electrical:
 - 3.1. Current Rating: 3A
 - 3.2. Voltage Rating: 20V Max.;
 - 3.3. Dielectric Withstanding voltage: 100Vac, 60S, 10mA;
 - 3.4. Contact resistance: 40m Ohms Max.;
 - 3.5. Insulation Resistance: 100M Ohms Min.;
4. Environmental:
 - 4.1. Operating temperature: -40°C~+85°C;
 - 4.2. Salt Spray Test: 24H Min. (No oxidation or rust);

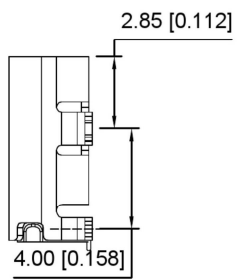

A1	GND	B12	GND
A4	VBUS	B9	VBUS
A5	CC1	B8	SBU2
A6	DP1	B7	DN2
A7	DN1	B6	DP2
A8	SBU1	B5	CC2
A9	VBUS	B4	VBUS
A12	GND	B1	GND
PIN	SIGNAL NAME	PIN	SIGNAL NAME

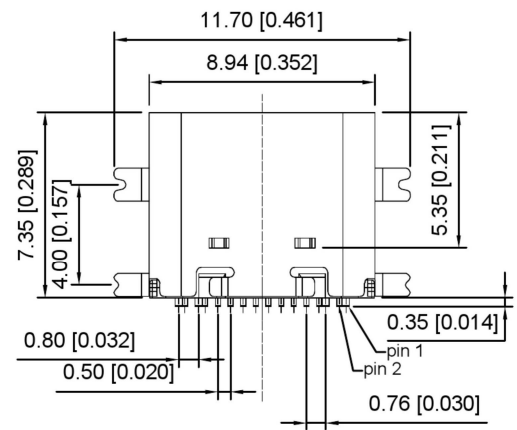
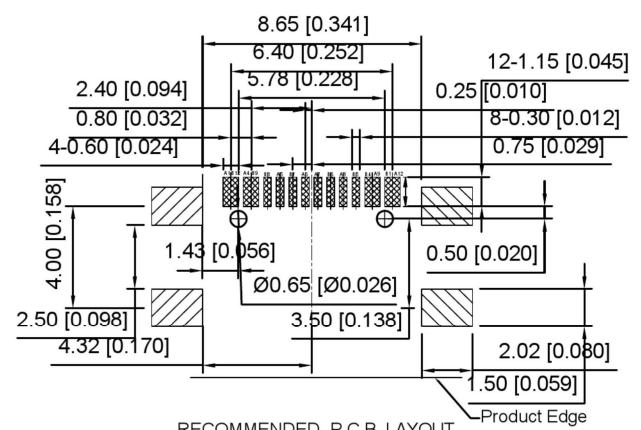
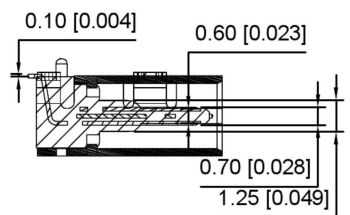
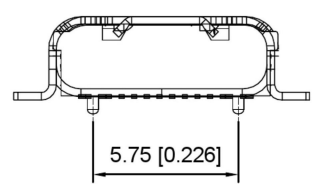

RECOMMENDED P.C.B LAYOUT
TOLERANCE UNSPECIFIED ±0.05mm

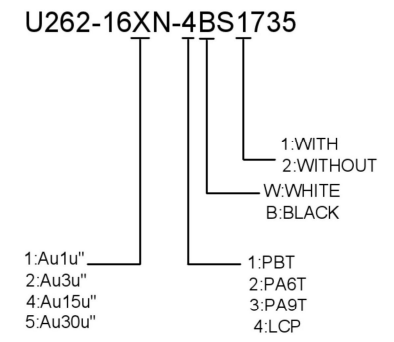

				ANGLAR	±5°	 SWITCH CONNECTOR	DSND	SCALE: N/A	MODEL TYPE:	Type-C 3.1
				L ≤ 4	±0.2		DWN	VIEW:	PART NO.:	
				4 < L ≤ 16	±0.3		CHKD	UNIT: mm/in	DWG NO.:	
				16 < L ≤ 63	±0.4		APPD	SIZE: A4		U262-16XN-4BS1735
				L > 63	±0.5					
REVISIONS				UNSPECIFIED TOLERANCES			KE SI DA ELECTRONIC TECHNOLOGY CO., LTD			
DATE				REVISED	APPROVED		WEIGHT	SHEET	REVISION	
WWW.BODONGKAIGUAN.NET				WWW.CKJACK.COM	WWW.KSDKG.COM			1/1		A0