

BOTTOM VIEW

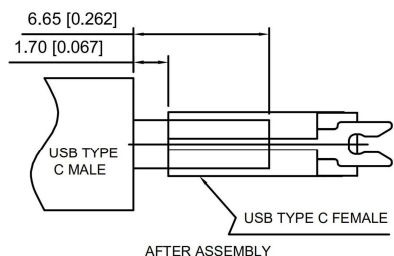

AFTER ASSEMBLY

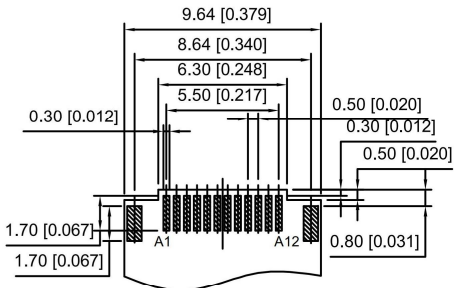
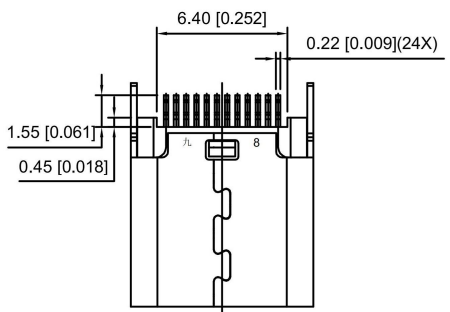
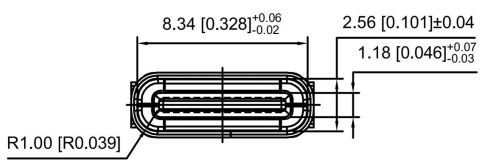

RECOMMENDED PCB LAYOUT(TOP VIEW)  
THICKNESS 0.80±0.05MM;DEFAULT TOLERANCE:±0.05

- NOTE:  
1.MATERIAL SPECIFICATION 材料规格:  
1.HOUSING 胶壳:LCP,UL94 V-0.  
2.TERMINAL 端子: COPPER ALLOY  
3.MID PLATE 中盘: STAINLESS STEEL  
4.FRONT SHELL 前壳: STAINLESS STEEL  
5.EMI PLATE EMI板: STAINLESS STEEL  
2.PLATING SPECIFICATION 电镀规格:  
2-1.TERMINAL 端子:  
Ni 50μ MIN. UNDER PLATED OVER ALL.  
Au PLATED ON THE FUNCTIONAL AREA OF CONTACT.  
(GOLD PLATING THICKNESS FOLLOW THE P/N)  
PLATING SPECIFICATIONS OF THE SOLDER AREA FOLLOW THE P/N  
2-2.FRONT SHELL 前壳:  
PLATING SPECIFICATIONS FOLLOW THE P/N  
2-3.MID PLATE&EMI PLATE 中盘&EMI板:  
CLEAR ONLY  
3.MECHANICAL PERFORMANCE 机械性能:  
3-1.INSERTION FORCE 插入力: 0.5~2.0kgf.  
3-2.REMOVAL FORCE 拔出力: 0.8kgf~2.0kgf.  
3-3.DURABILITY 寿命: 10000 CYCLES.  
4.ELECTRICAL PERFORMANCE 电气性能:  
4-1.VOLTAGE RATING 额定电压:5 V DC/AC (RMS. max)  
CURRENT RATING 额定电流:5 AMPS. FOR TOTAL VBUS/GND PINS;  
1.25AMPS FOR CC PIN,0.25 AMPS. FOR ALL OTHER CONTACT.  
4-2. LLCR 接触电阻:  
VBUS & GND PINS AND OTHER PINS: 40mΩ/PIN MAX.  
SHIELD: 50mΩ/MAX.  
LLCR MAX. CHANGE OF ALL PINS: 10mΩ.  
4-3.INSULATION RESISTANCE 绝缘电阻: 100MΩ MIN  
4-4.DIELECTRIC WITHSTAND VOLTAGE 介电耐压:AC 100V FOR 1 MINUTE.  
5.ENVIRONMENTAL PERFORMANCE 环保性能:  
OPERATING TEMPERATURE 工作温度:-25°C~+85°C.  
6.IR REFLOW 红外线回流焊:  
THE PEAK TEMPERATURE ON THE BOARD SHALL  
BE MAINTAINED FOR 10 SECONDS AT 260°C.

XKB Connectivity

A1	GND	B12	GND
A2	SSTXP1	B11	SSRXP1
A3	SSTXN1	B10	SSRXN1
A4	VBUS	B9	VBUS
A5	CC1	B8	SBU2
A6	DP1	B7	DN2
A7	DN1	B6	DP2
A8	SBU1	B5	CC2
A9	VBUS	B4	VBUS
A10	SSRXN2	B3	SSTXN2
A11	SSRXP2	B2	SSTXP2
A12	GND	B1	GND
PIN	SIGNAL NAME	PIN	SIGNAL NAME

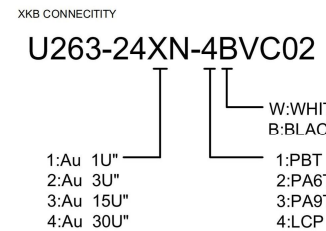

REVISIONS				DATE	REVISED	APPROVED	UNSPECIFIED TOLERANCES	DSND	SCALE: N/A	MODEL TYPE: Type-C 3.1	
							ANGULAR ±5°	DWN	VIEW:	PART NO.:	
							L ≤ 4 ±0.2	CHKD	UNIT: mm/in	DWG NO.:	
							4 < L ≤ 16 ±0.3	APPD	SIZE: A4	U263-24XN-4BVC02	
							16 < L ≤ 63 ±0.4				
							L > 63 ±0.5				
WWW.BODONGKAIGUAN.NET				WWW.CKJACK.COM	WWW.KSDKG.COM	KE SI DA ELECTRONIC TECHNOLOGY CO., LTD			WEIGHT	SHEET	REVISION
									1/1	A0	

