

### Circuit diagram

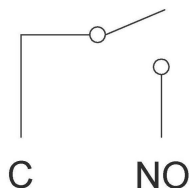

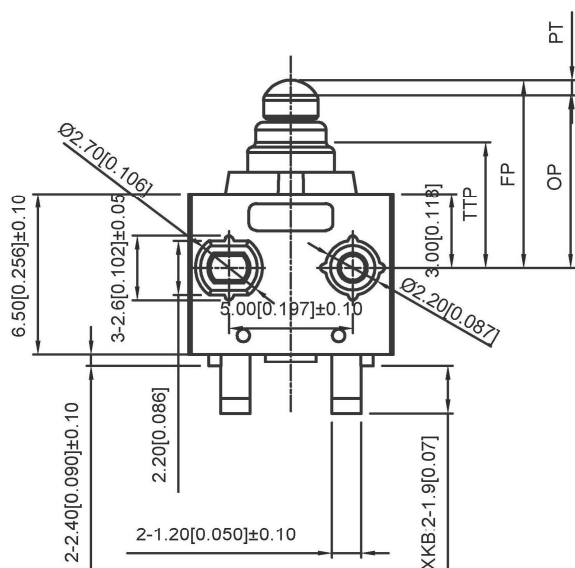
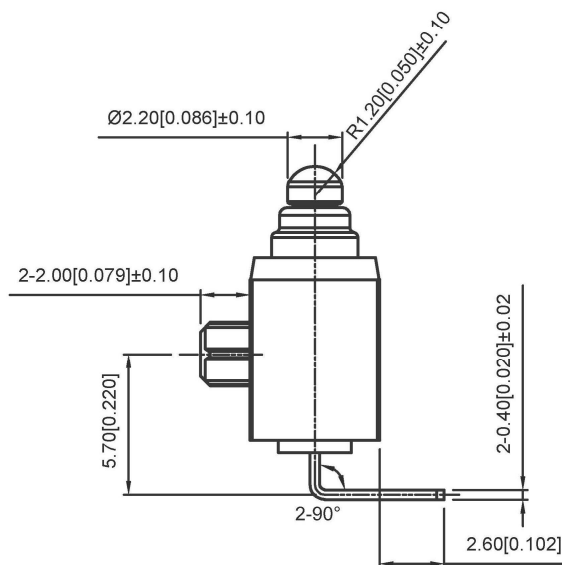
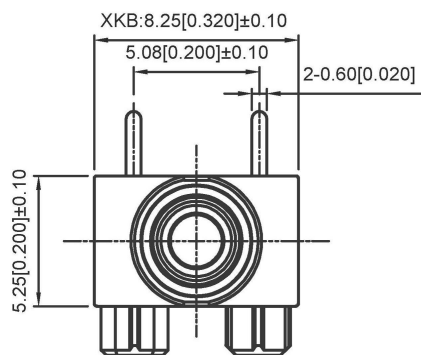

### Technical Parameters

1. Electrical Rating: 0.1A 125/250VAC  
0.1A/12VDC
2. Electrical lifetime: 100 000
3. Mechanical lifetime: 100 000
4. Contact Resistance:  $\leq 50\text{m}\Omega$
5. Operating force: 1.5N MAX
6. Free Position: 7.6mm MAX
7. Operation Position:  $7.1 \pm 0.3\text{mm}$
8. TTP: 5.1mm Min
9. Withstand Voltage: Feet and Feet 500V/5S/5mA  
Feet and Shell 1500/5S/5mA
10. Insulation Resistance:  $\geq 100\text{M}\Omega$  (Test Voltage 500VDC)
11. Proof Tracking Index (PTI): 175V



Waterproof grade: IP67

|   |                        |              |
|---|------------------------|--------------|
| 1 | Rubber shell           | PA66         |
| 2 | seal ring              | Silica gel   |
| 3 | base                   | Brass+PA66   |
| 4 | According to sincerity | POM          |
| 5 | Contact moving plate   | C5191+AgNi10 |
| 6 | Strut                  | SUS301-H     |

|                       |  |  |  |                |         |   |                        |   |   |             |             |       |          |
|-----------------------|--|--|--|----------------|---------|---|------------------------|---|---|-------------|-------------|-------|----------|
|                       |  |  |  | ANGLAR         | ±5°     | <br>SWITCH CONNECTOR | DSND                   |   | SCALE: N/A  | MODEL TYPE: | Microswitch |       |          |
|                       |  |  |  | L ≤ 4          | ±0.2    |   | DWN                    |   | VIEW:  | PART NO.:   | DF1-CZ-3    |       |          |
|                       |  |  |  | 4 < L ≤ 16     | ±0.3    |   | CHKD                   |   | UNIT: mm/in   | DWG NO.:    |             |       |          |
|                       |  |  |  | 16 < L ≤ 63    | ±0.4    |   | APPD                   |   | SIZE: A4  |             |             |       |          |
|                       |  |  |  | L > 63         | ±0.5    |   |                        |   |   |             |             |       |          |
| REVISIONS             |  |  |  | DATE           | REVISED | APPROVED  | UNSPECIFIED TOLERANCES |   |   |             | WEIGHT      | SHEET | REVISION |
| WWW.BODONGKAIGUAN.NET |  |  |  | WWW.CKJACK.COM |         | WWW.KSDKG.COM   |                        | KE SI DA ELECTRONIC TECHNOLOGY CO., LTD |   |             |             | 1/1   | A0       |