

### S: Scrolls

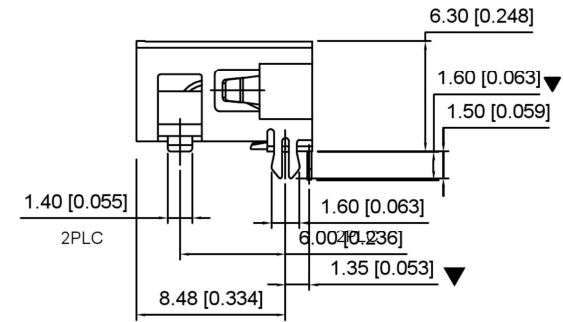
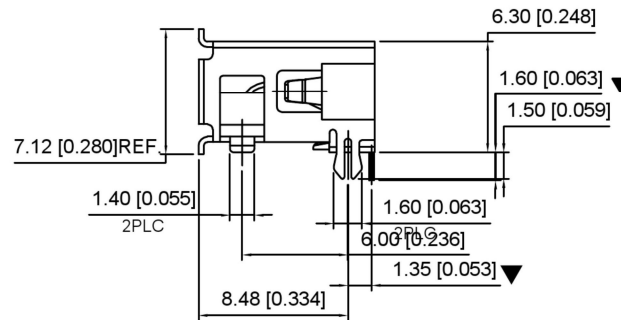
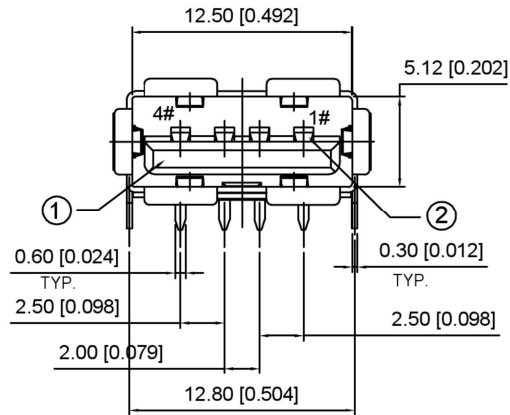
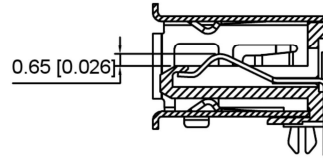

### F: Flat

Housing Material: PA9T UL94V-0, Black  
 Contact Terminal: COPPER ALLOY. (T=0.25mm)  
 Metallic Shell: Brass(T=0.30mm)

				ANGLAR	±5°	DSND		SCALE: N/A	MODEL TYPE:	USB 2.0			
				L ≤ 4	±0.2	DWN		VIEW:	PART NO.:				
				4 < L ≤ 16	±0.3	CHKD		UNIT: mm/in	DWG NO.:				
				16 < L ≤ 63	±0.4	APPD		SIZE: A4	U221-04XN-3BU06-X5				
				L > 63	±0.5					WEIGHT	SHEET	REVISION	
DESCRIPTION				DATE	REVISED	APPROVED	UNSPECIFIED TOLERANCES						
REVISIONS								KE SI DA ELECTRONIC TECHNOLOGY CO., LTD				1/1	A0
WWW.BODONGKAIGUAN.NET				WWW.CKJACK.COM				WWW.KSDKG.COM					

