

REV.	ECN.NO.	MODIFY.CONTENT	DATE
A		FIRST VERSION	04/12'19
B		Modify Housing	07/12'19

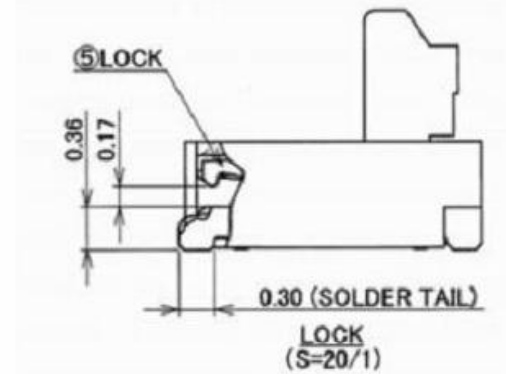

EVEN NUMBER POS.

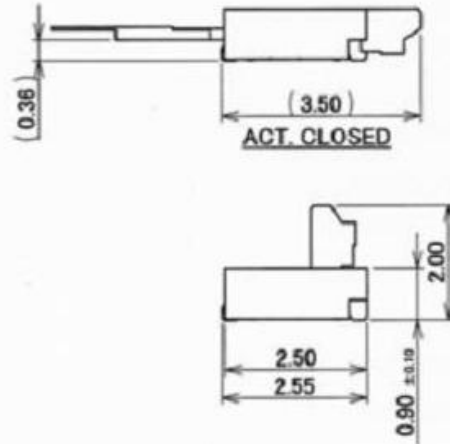
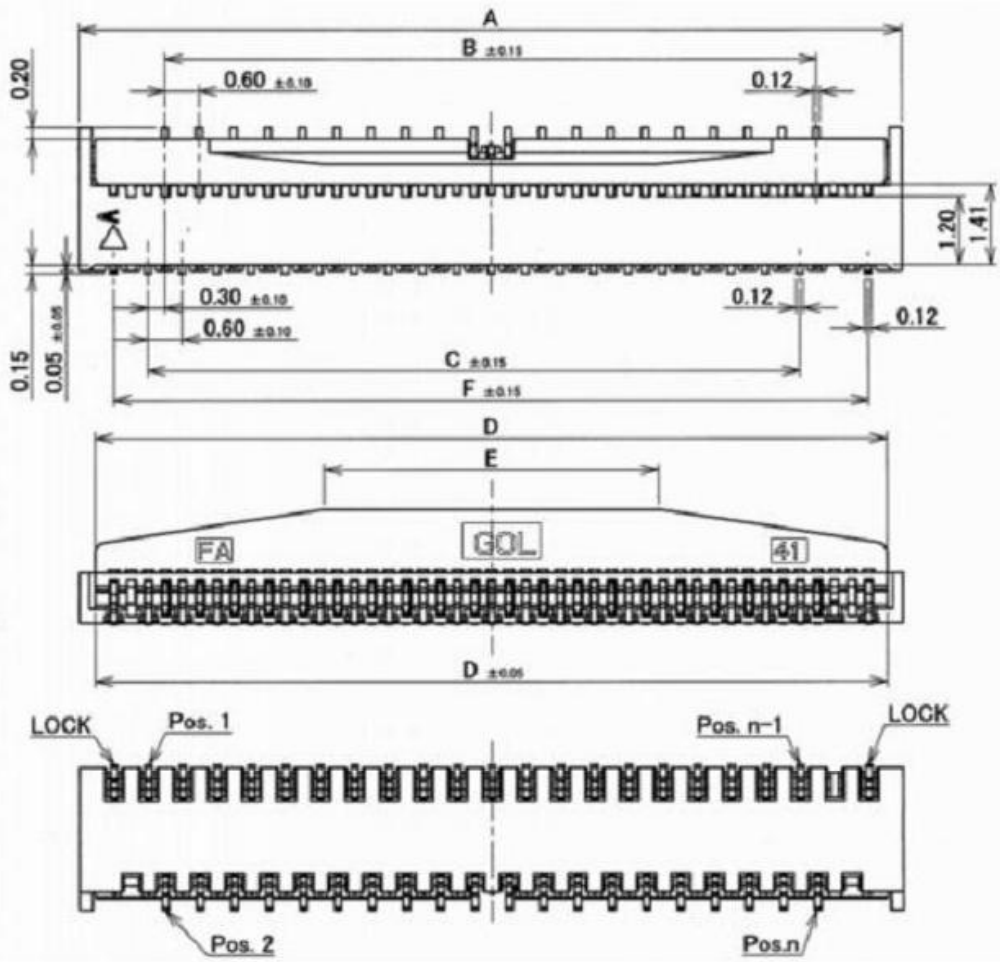
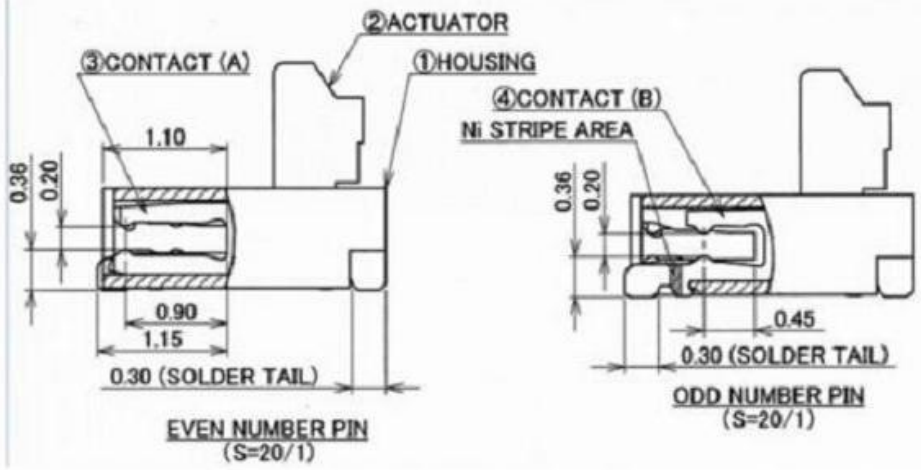

Pos.	A	B	C	D	E	F
30P	11.40	8.40	8.40	10.85	6.85	10.20
34P	12.60	9.60	9.60	12.05	8.05	11.40
38P	13.80	10.80	10.80	13.25	5.25	12.60
40P	14.40	11.40	11.40	13.85	5.85	13.20
50P	17.40	14.40	14.40	16.85	8.85	16.20
56P	19.20	16.20	16.20	18.65	10.65	18.00

GENERAL TOLERANCE		DRAWN	SCALE	PART NO.
X±0.30	x.*±3.0'	CHECKED	8/1	TITLE
.X±0.25	.x'±2.0'	APPROVED	UNITS	mm
.XX±0.20		File NO.	P0301401S	CUSTOMER DRAWING
.XXX±0.10		REV.		
SHEET	2/5	QTY	1	B

广东科斯达开关厂

此文件为双方检验的唯一标准
This document is the only standard for inspection by both parties.

REV.	ECN.NO.	MODIFY.CONTENT	DATE
A		FIRST VERSION	04/12'19
B		Modify Housing	07/12'19

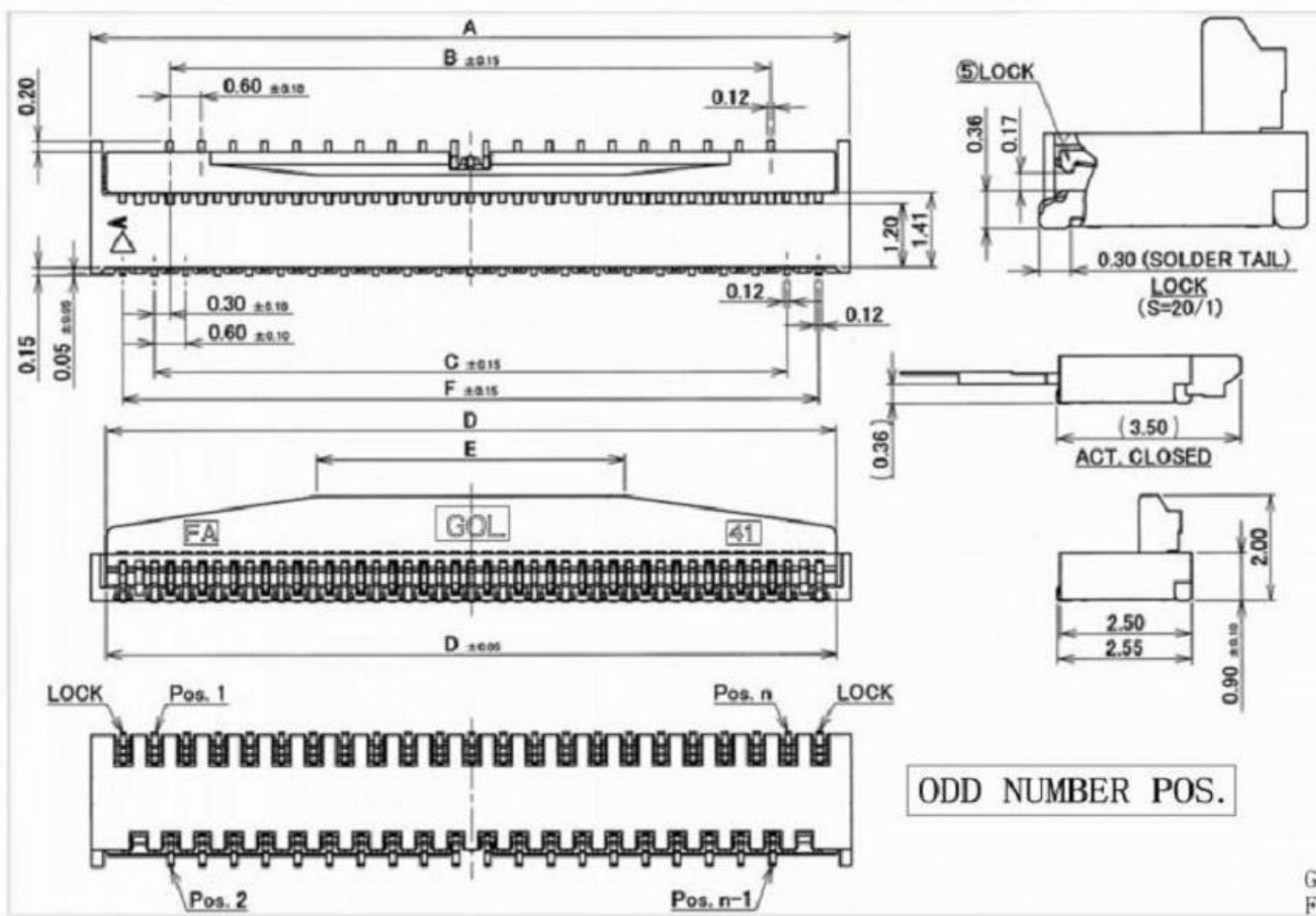

Pos.	A	B	C	D	E	F
29P	10.80	7.80	8.40	10.25	6.25	9.60
31P	11.40	8.40	9.00	10.85	6.85	10.20
35P	12.60	9.60	10.20	12.05	8.05	11.40
37P	13.20	10.20	10.80	12.65	4.65	12.00
39P	13.80	10.80	11.40	13.25	5.25	12.60
41P	14.40	11.40	12.00	13.85	5.85	13.20
45P	15.60	12.60	13.20	15.05	7.05	14.40
47P	16.20	13.20	13.80	15.65	7.65	15.00
51P	17.40	14.40	15.00	16.85	8.85	16.20
53P	18.00	15.00	15.60	17.45	9.45	16.80
57P	19.20	16.20	16.80	18.65	10.65	18.00
61P	20.40	17.40	18.00	19.85	11.85	19.20
63P	21.00	18.00	18.60	20.45	8.45	19.80
71P	23.40	20.40	21.00	22.85	10.85	22.20

NOTES:
 Current Rating: 0.2A AC/DC
 Voltage Rating: 50V AC/DC Max
 Temperature Range: -30°C~+85°C
 Contact Resistance: 60 mΩ Max
 Insulation Resistance: 100 MΩ Min
 Withstanding Voltage: 250V AC/minute

ODD NUMBER POS.

Gold plating ————
 F: lu" min ————
 PIN number ————

OO: Rohs
 HF: HALOGEN FREE
 Reel packing
 Natural color

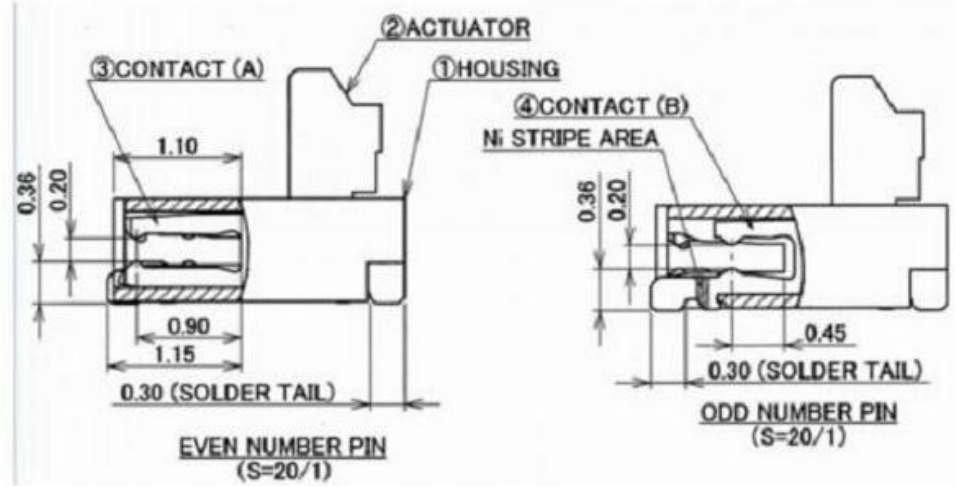

NO.	DISCRIPTION	MATERIAL	FINISH, REMARKS
5	LOCK	PHOSPHOR BRONZE	SOLDERING AREA : Au 0.03 μm MIN. OVER Ni 1.00 μm MIN.
4	CONTACT (B)	PHOSPHOR BRONZE	SEE TABLE 1, WITH Ni STRIPE
3	CONTACT (A)	PHOSPHOR BRONZE	SEE TABLE 1
2	ACTUATOR	LCP	UL94V-0, BEIGE
1	HOUSING	LCP	UL94V-0, BEIGE

GENERAL TOLERANCE		DRAWN	SCALE	PART NO.
X.±0.30	x.*±3.0'	CHECKED	8/1	TITLE
.X±0.25	.x'±2.0'	APPROVED	UNITS	m/m
.XX±0.20		File NO.	PO301401S	CUSTOMER DRAWING
.XXX±0.10		REV.		
SHEET	1/5	Q'TY	1	B

广东科斯达开关厂

此文件为双方检验的唯一标准
 This document is the only standard for inspection by both parties.