

REV.	ECN.NO.	MODIFY.CONTENT	DATE
A		FIRST VERSION	03/25'20

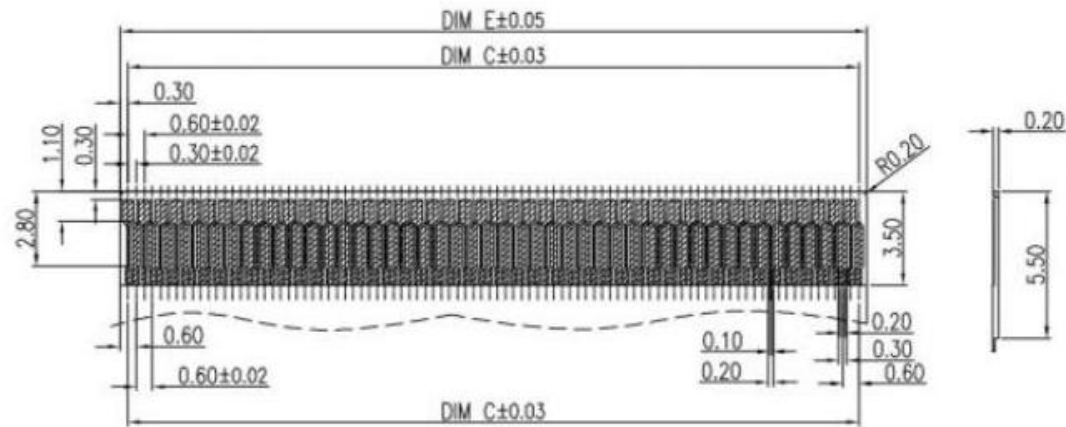

Recommended FPC/FFC Dimension

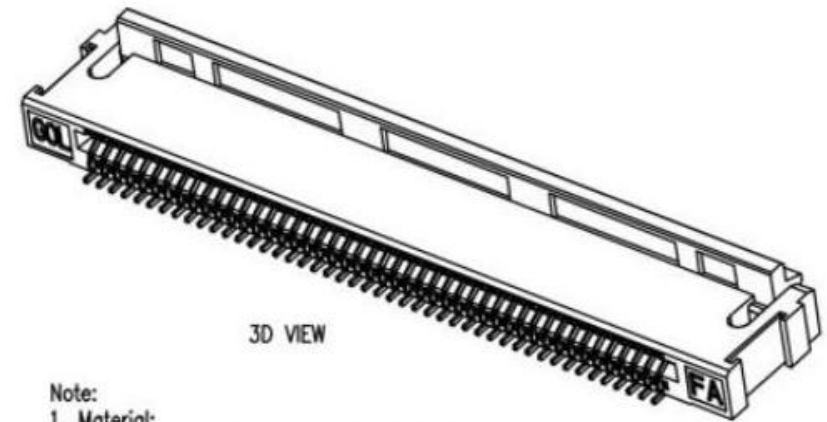

3D VIEW

Note:

- Material:
  - Insulator : Hi-Temp Plastics UL94V-0
  - Lock Lever : Hi-Temp Plastics UL94V-0 Color: black/brown.
  - Terminal A: copper alloy.
  - Terminal B: copper alloy.
- Finish:
  - Terminal Underplating: Gold flash overall.
- Product must comply HF RoHS specification.
- Rating:
  - Operating Voltage: 50V AC/DC.
  - Current Rating: 0.2A AC/DC.
  - Operating Temperature: -40°C~+85°C.
  - Contact resistance: 50mΩ Max(Initial)
  - Insulation resistance: 50MΩ Min
  - Withstand voltage: 200V AC/minute
- Product No:

1 F 03015

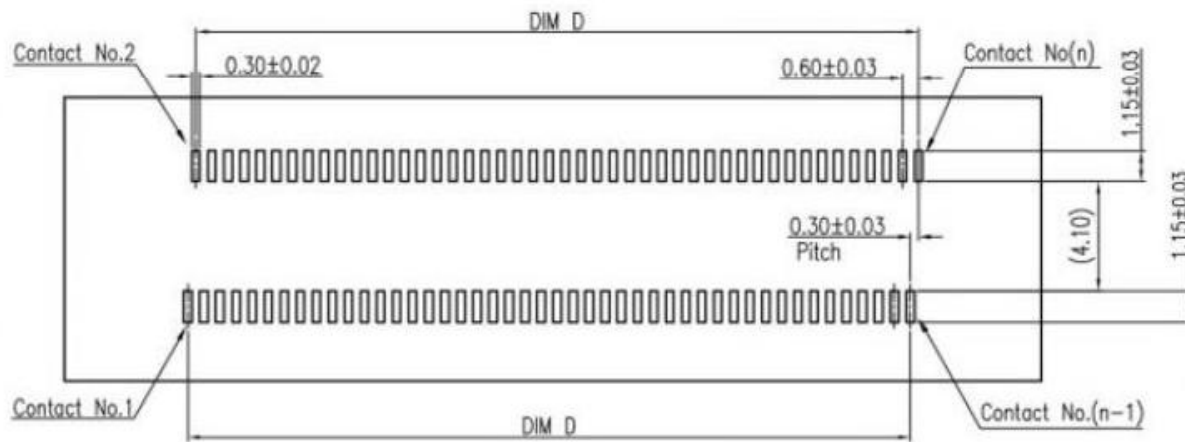

Recommended PCB and Metal Dimension  
(Connector Mounting Surface)

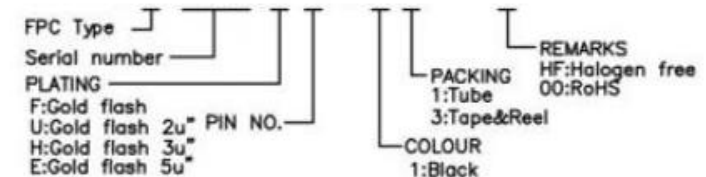

GENERAL TOLERANCE		DRAWN	Jon xia	03/25'20	SCALE	PART NO.
X±0.30	x.'±3.0'	CHECKED	Shengjie Chu	03/25'20	1/1	TITLE
.X±0.25	.x'±2.0'	APPROVED	Cunfa Lai	03/25'20	UNITS	mm
.XX±0.20		File NO.	F0301501S		CUSTOMER DRAWING	
.XXX±0.10		REV.				
SHEET	2/3	QTY	1	A	广东科斯达开关厂	

REV.	ECN.NO.	MODIFY.CONTENT	DATE
A		FIRST VERSION	03/25'20

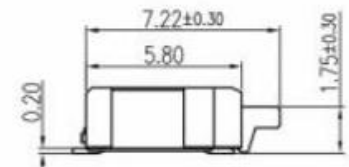
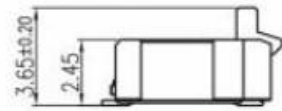
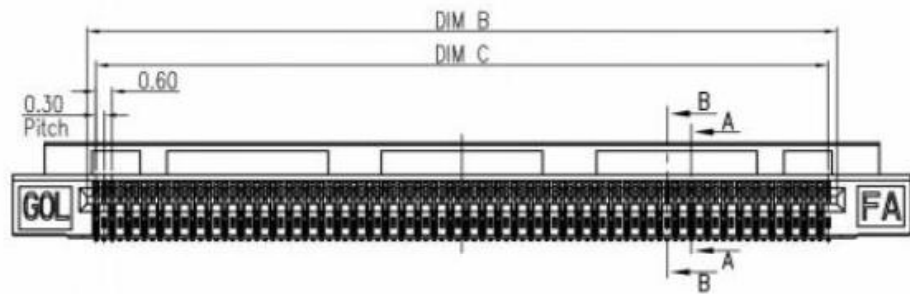
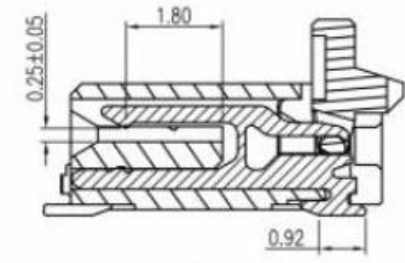
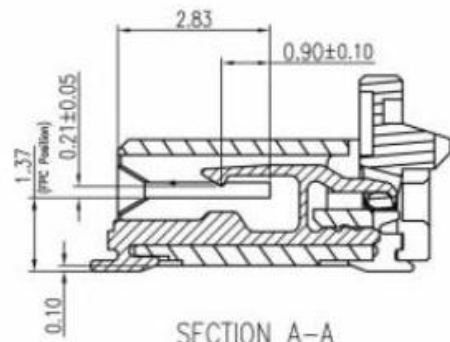
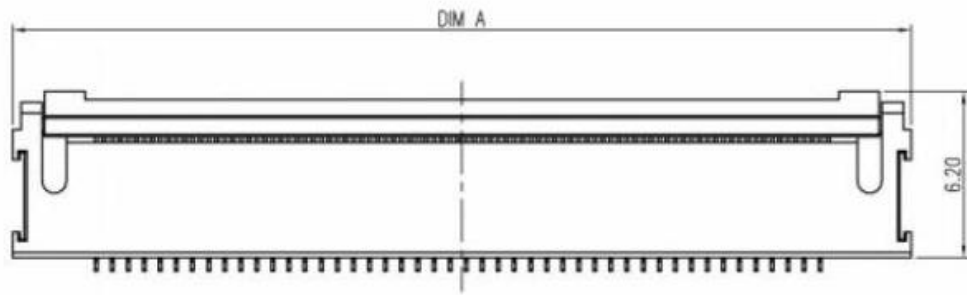

STYLE OF LOCK LEVER OPEN

STYLE OF LOCK LEVER CLOSE

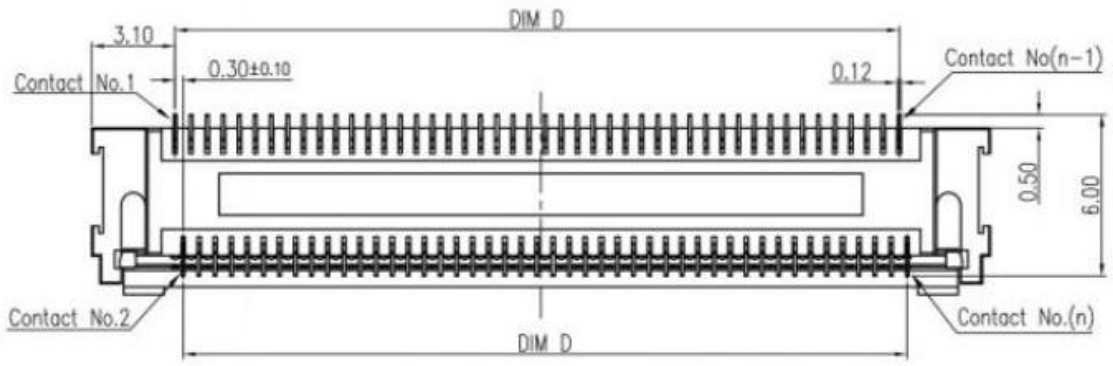

TABLE OF DIM.

PART No.	DIM A	DIM B	DIM C	DIM D	DIM E
84	31.10	25.55	24.90	24.60	25.50
92	33.50	27.95	27.30	27.00	27.90

GENERAL TOLERANCE		DRAWN	Jon xia	03/25'20	SCALE	PART NO.
X.±0.30	x.'±3.0'	CHECKED	Shengjie Chu	03/25'20	1/1	TITLE
.X±0.25	.x'±2.0'	APPROVED	Cunfa Lai	03/25'20	UNITS	mm
.XX±0.20		File NO.	F0301501S	CUSTOMER DRAWING		
.XXX±0.10		REV.				
SHEET	1/3	Q'TY	1	REV.	A	

广东科斯达开关厂

This document is the only standard for inspection by both parties.

REV.	ECN.NO.	MODIFY.CONTENT	DATE
A		FIRST VERSION	03/25' 20

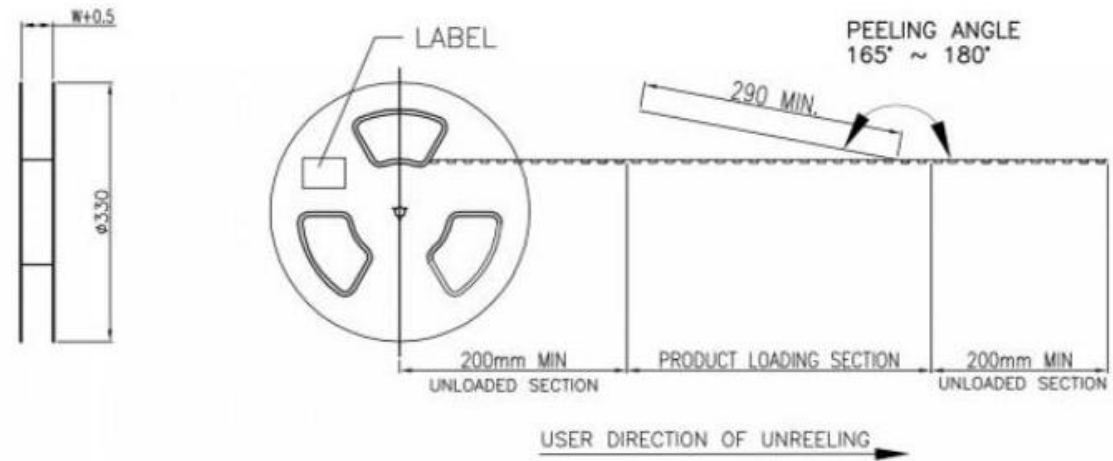

- NOTES :
- MATERIAL :  
COVER TAPE : P.S T=0.05mm  
CARRIER TAPE : P.S T=0.40mm  
CARTON: CORRUGATED FIBER
  - DIMENSION :  
REEL : SEE DRAWING  
SHIPPING BOX: 350X350X300mm
  - QUANTITY : SEE TABLE
  - PEELING RESISTANCE : 10gf~130gf
  - PEELING SPEED : 300mm/MINUTES

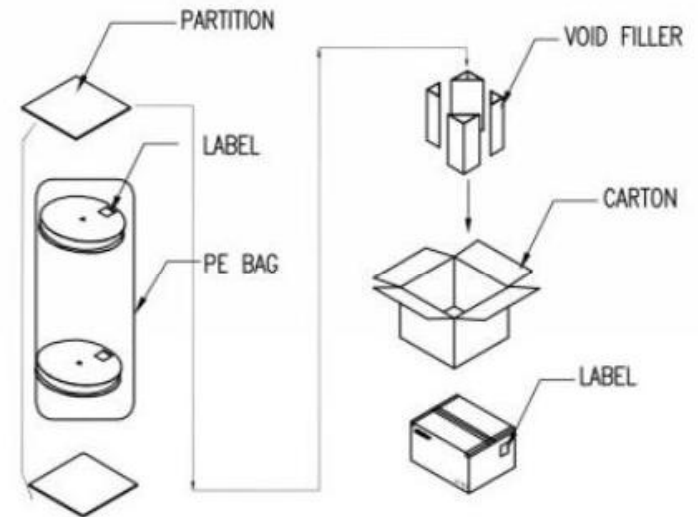
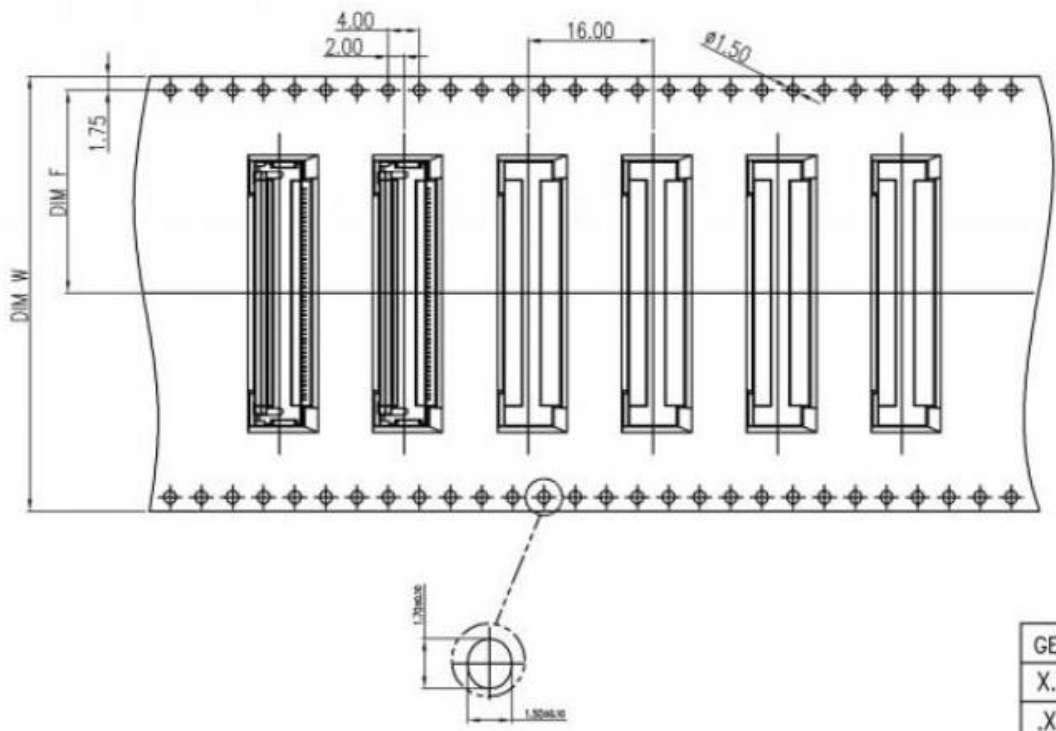

TABLE OF DIM.

POS.	PCS/REEL	BOX/REEL	DIM W	DIM F
84	1000	5000	44	20.20
92	1000	4000	56	26.20

GENERAL TOLERANCE		DRAWN	Jon xia	03/25'20	SCALE	PART NO.	CUSTOMER DRAWING
X.±0.30	x.'±3'	CHECKED	Shengjie Chu	03/25'20	1/1	TITLE	
.X±0.25	.x'± 2'	APPROVED	Cunfa Lai	03/25'20	UNITS	mm	
.XX±0.20		File NO.	F0301501S				
.XXX±0.10		REV.					
SHEET	3/3	Q'TY	1	REV.	A		

广东科斯达开关厂