

REV.	ECN.NO.	MODIFY.CONTENT	DATE
A		FIRST VERSION	2/23'21

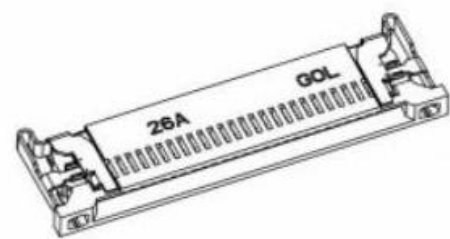

3D VIEW

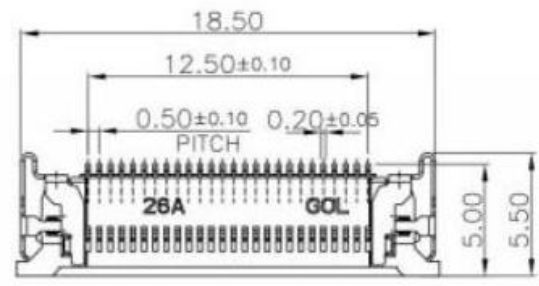
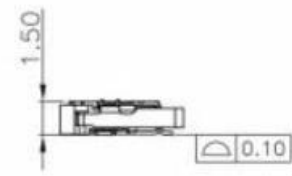
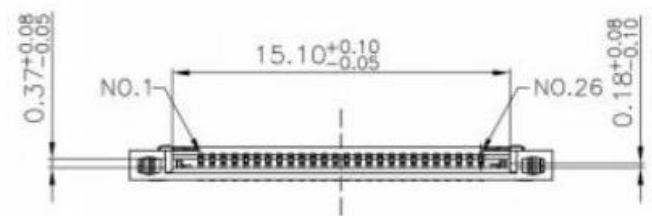

NOTES:
 Insulator: LCP , UL 94V-0
 Shell: STAINLESS STEEL/Au-Plated
 Terminal: PHOSPHOR COPPER/Au-Plated
 Current Rating: 0.5A AC,DC
 Voltage Rating: 200V AC,DC
 Temperature range: -40°C~+85°C
 Contact resistance: 60mΩ Max
 Insulation resistance: 100MΩ Min
 Withstand voltage: 250V,AC/minute

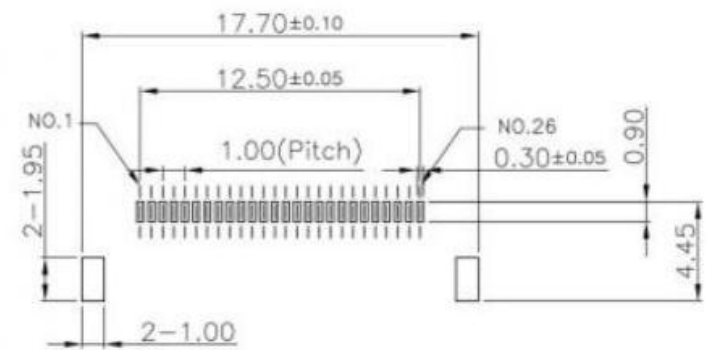
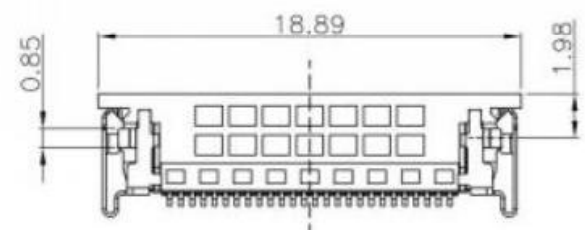

RECOMMEND PCB LAYOUT
 DEFAULT TOL:±0.05

GENERAL TOLERANCE		DRAWN	Wilson Sun	02/23'21	SCALE	PART NO.
X.±0.30	x.*±3.0'	CHECKED	SHENGJIE CHU	02/23'21	1/1	TITLE
.X±0.25	.x'±2.0'	APPROVED	CUNFA LAI	02/23'21	UNITS	mm
.XX±0.20		File NO.				CUSTOMER DRAWING
.XXX±0.10		REV.				
SHEET	1/3	Q'TY	1	A		

广东科斯达开关厂

REV.	ECN.NO.	MODIFY.CONTENT	DATE
A		FIRST VERSION	02/23' 21

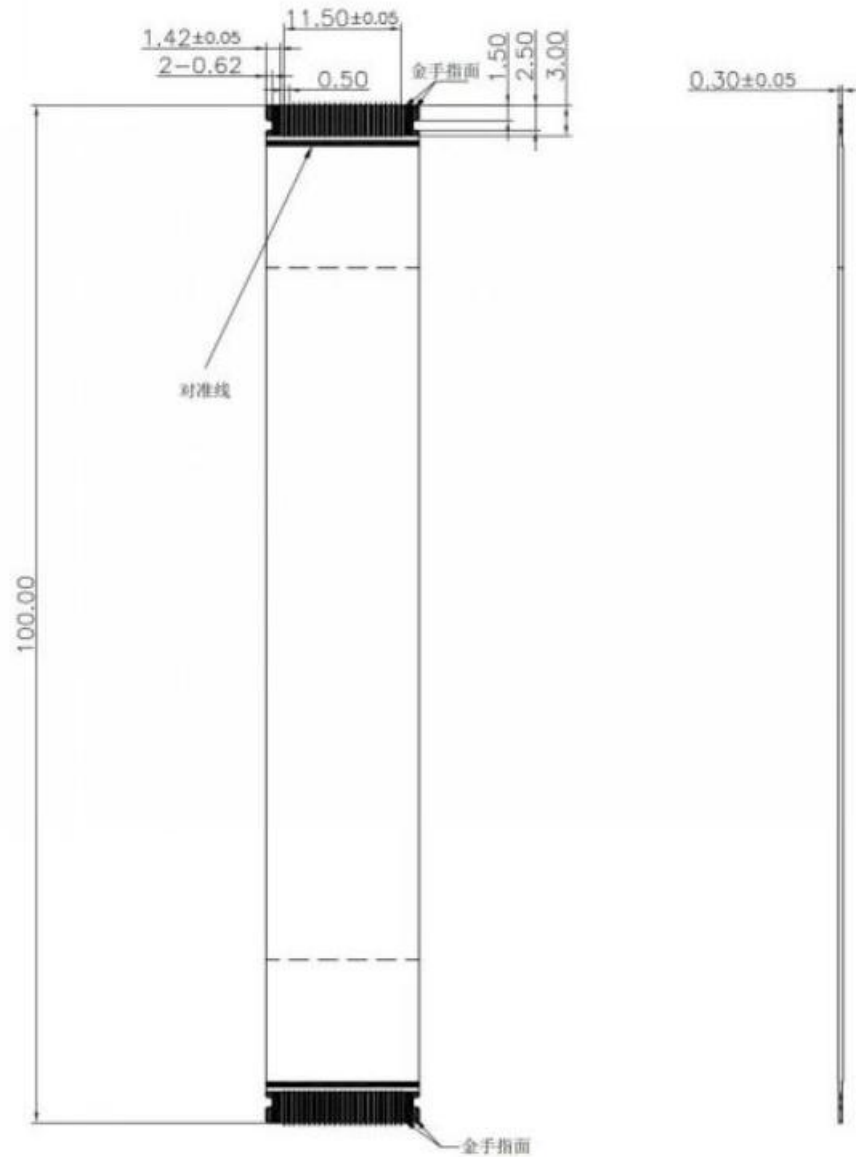

RECOMMENDED FPC DIMENSION

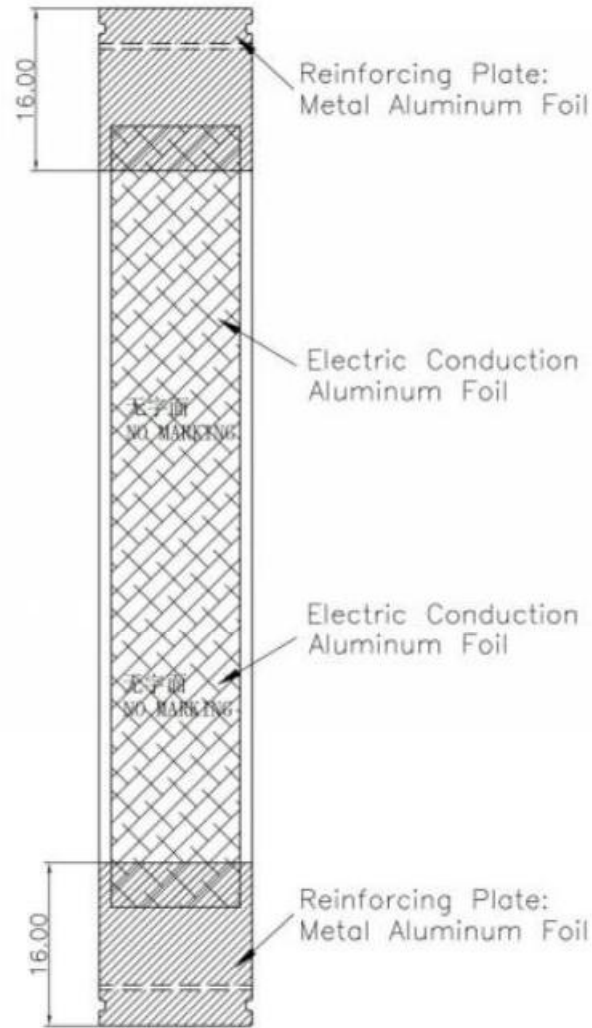

GENERAL TOLERANCE		DRAWN	Wilson Sun	02/23'21	SCALE	1/1	PART NO.	
X.±0.30	x.'±3"	CHECKED	SHENGJIE CHU	02/23'21	TITLE	0.5 Pitch B=1.5 Auto-Lock FPC		
.X±0.25	.x'± 2"	APPROVED	CUNFA LAI	02/23'21	UNITS	mm		
.XX±0.20		File NO.						
.XXX±0.10		REV.						
SHEET	2/3	Q'TY	1	A	广东科斯达开关厂			

REV.	ECN.NO.	MODIFY.CONTENT	DATE
A		FIRST VERSION	02/23' 21

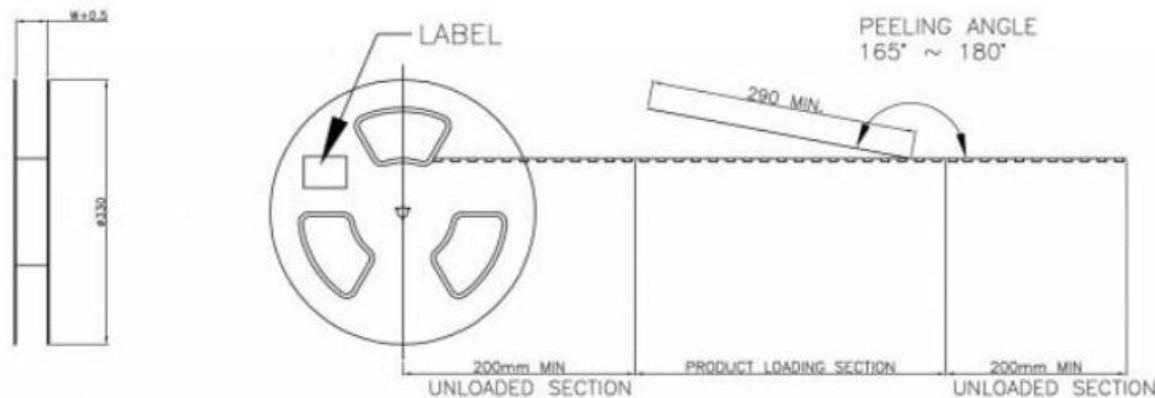

NOTES :

- MATERIAL :
COVER TAPE : P.S T=0.05mm
CARRIER TAPE : P.S T=0.35mm
CARTON: CORRUGATED FIBER
- DIMENSION :
REEL : SEE DRAWING
SHIPPING BOX: 350X350X300mm
- QUANTITY : SEE TABLE
- PEELING RESISTANCE : 10gf~130gf
- PEELING SPEED : 300mm/MINUTES

USER DIRECTION OF UNREELING

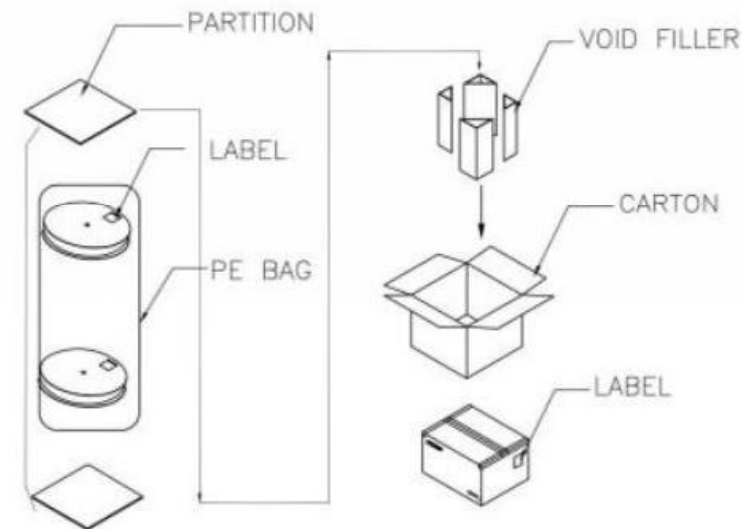
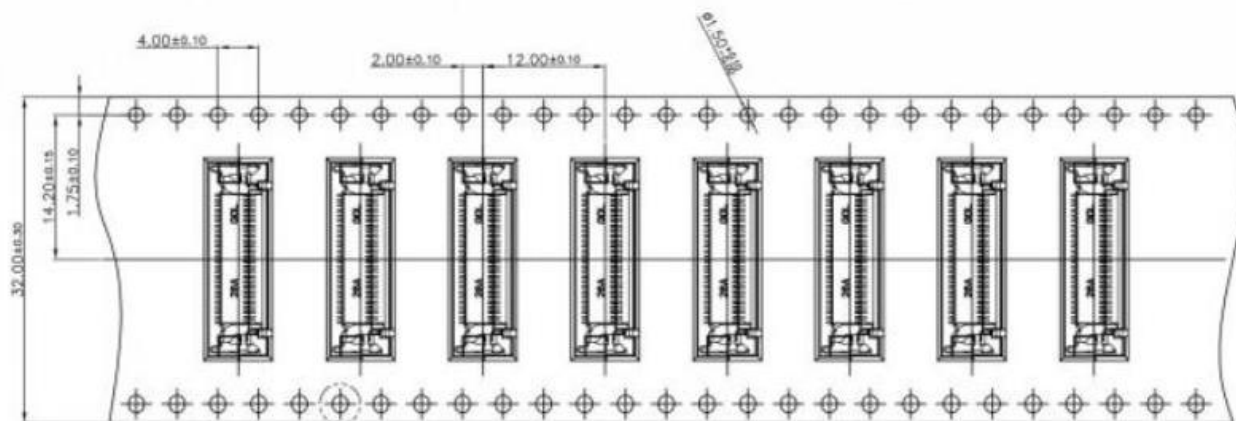
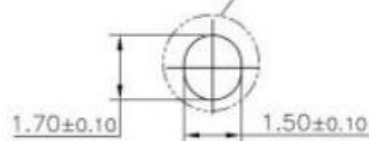

TABLE OF DIM.

POS.	PCS/REEL	BOX/REEL
26	2400	16800



GENERAL TOLERANCE		DRAWN	Wilson Sun	02/23'21	SCALE	PART NO.	
X±0.30	x.±3"	CHECKED	SHENGJIE CHU	02/23'21	1/1	TITLE	0.5 Pitch H=1.5 Auto-Lock FPC
.X±0.25	.x± 2"	APPROVED	CUNFA LAI	02/23'21	UNITS	mm	CUSTOMER DRAWING
.XX±0.20		File NO.					
.XXX±0.10		REV.					
SHEET	3/3	Q'TY	1	A			

广东科斯达开关厂