

RoHS

REV	ECN NO	DESCRIPTION	DATE	NAME
A		NEW		

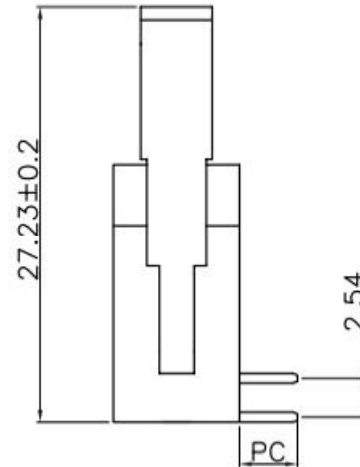
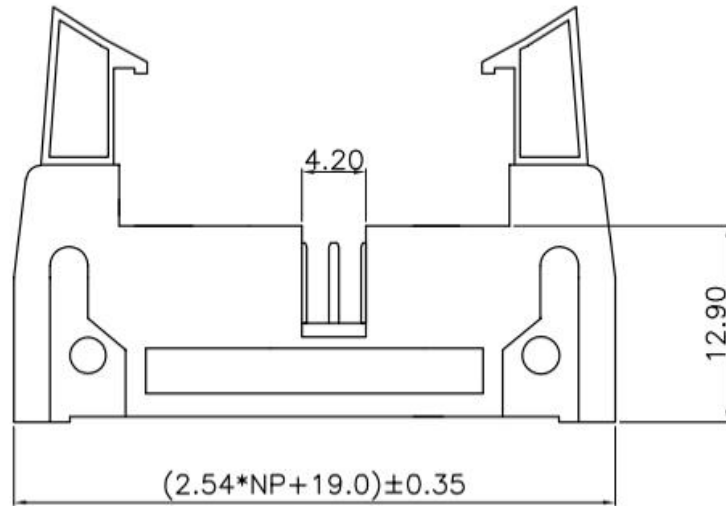
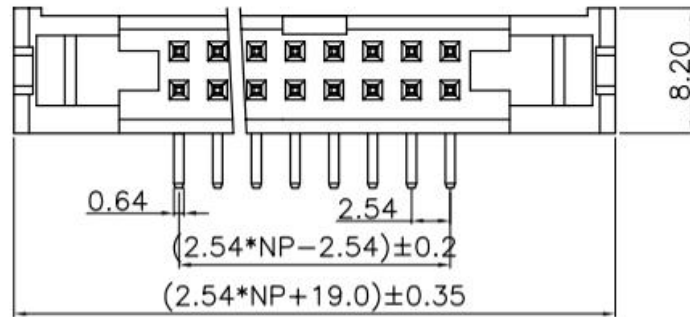

1. MATERIALS AND FINISH
 - 1.1 HOUSING MATERIALS: Asfollows
 - 1.2 CONTACTS: Brass
 - 1.3 PLATING: Asfollows
2. SPECIFICATIONS
 - 2.1 CURRENT RATING: 3AMP
 - 2.2 INSULATION RESISTANCE: 1000MΩ
 - 2.3 DIELECTRIC WITHSTANDING VOLTAGE: 1000V AC/DC.
 - 2.4 OPERATING TEMPERATURE: -40°C TO +105°C.

Ordering Information

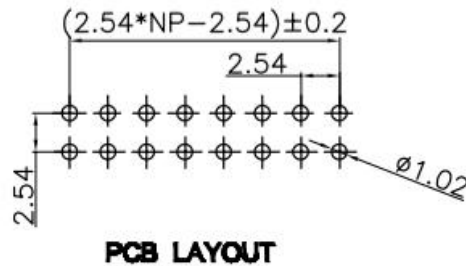
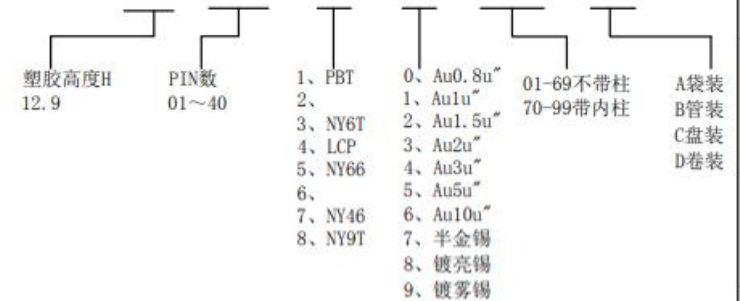

STANDARD TOLERANCE (EXCEPT SPECIFIED)			
LINER		ANGLES	
.0	±0.30	0.°	±3°
.00	±0.20	.0°	±2°
.000	±0.10	.00°	±1°

广东科斯达开关厂

TITLE		2.54 Ejector Header Right Angle Type		DRAWN BY		ZSL		18.10.13	
PART NO				CHECKED BY					
DRAWING NO				APPROVED BY					
SCALE	1:1	UNIT	mm		PAGE	1/1	SIZE	A4	