

RoHS

REV	ECN NO	DESCRIPTION	DATE	NAME
A		NEW		

Specifications

- 1.Current Rating:3Amps
- 2.Contact Resistance: 20mΩ
- 3.Insulator Resistance:1000 Megohms min.
- 4.Dielectric withstanding Voltage: AC/DC 1000V
- 5.Operating Temperature:-40℃ to+105℃
- 6.Contact Material: Copper alloy
- 7.Insulator Material:Asfollows
- 8.Plated: Asfollows

Ordering Information

Insulation Height*Wide (H*W) Option: 85=8.5*6.0	NO. of Pins Per Row: 1-40P	Insulation Material Option: 1=PBT 2=PPS 3=NY6T 4=LCP 5=NY66 6=Customized 7=NY46 8=NY9T	Contact Plating 0=0.8" Gold 1=Au1" Gold 2=Au1.5" Gold 3=Au2" Gold 4=Au3" Gold 5=Au5" Gold 6=Customized 7=Gold/Tin 8=Tin	Serial NO. 01-69(No pillars) 70-89(pillars) 90-99(outside pillars)	Packing A=PE Bag B=Tube C=Tray D=Reel
---	-------------------------------	---	--	---	---

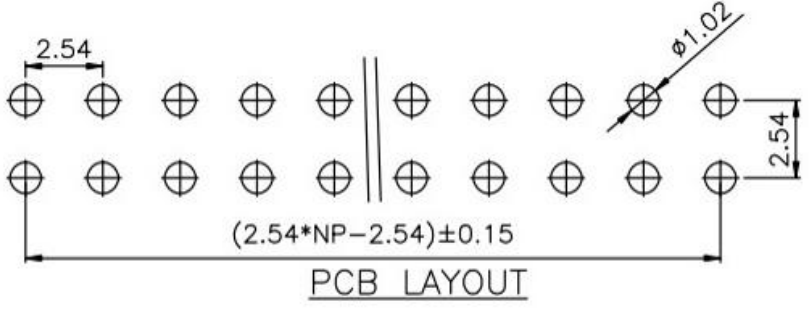
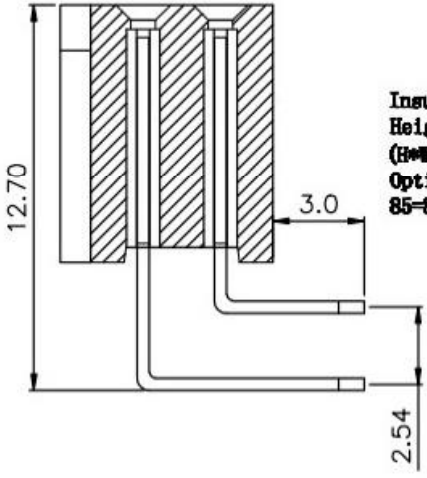
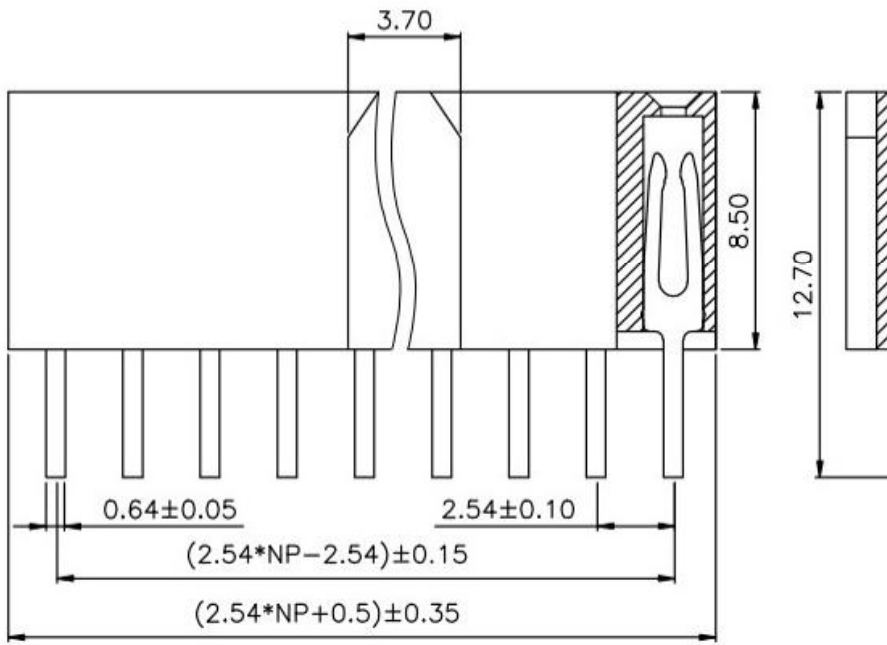
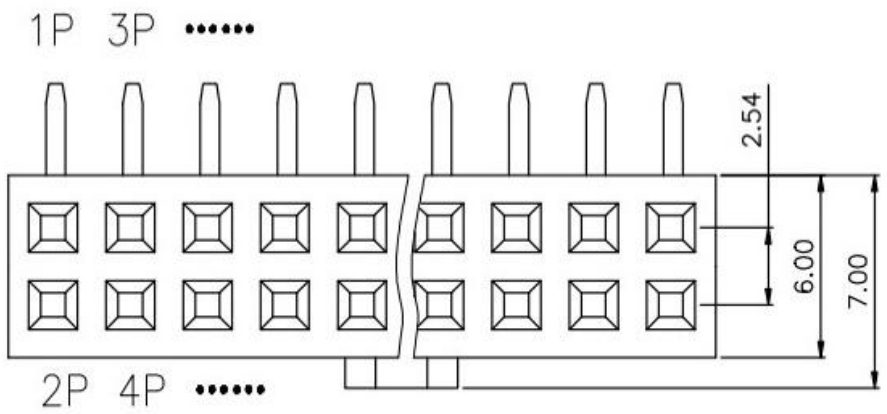

STANDARD TOLERANCE (EXCEPT SPECIFIED)	
LINER	ANGLES
.0 ±0.30	0.° ±3°
.00 ±0.20	.0° ±2°
.000 ±0.10	.00° ±1°

广东科斯达开关厂

TITLE	PH2.54mm 2XNP 90° Dual row Female Header Y Type With embossment	DRAWN BY	Lu junhui	18.04.09
PART NO		CHECKED BY		
DRAWING NO		APPROVED BY		
SCALE	1:1	UNIT	mm	PAGE 1/1
				SIZE A4