

REV	ECN NO	DESCRIPTION	DATE	NAME
A	—	NEW	11/28-'19	LZM

RoHS

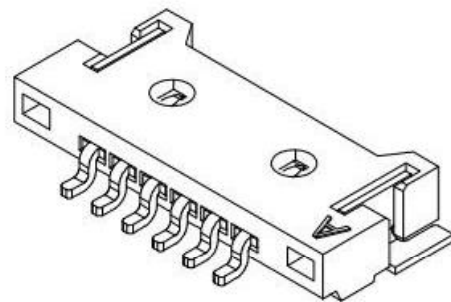
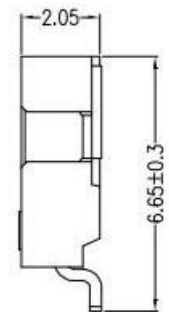
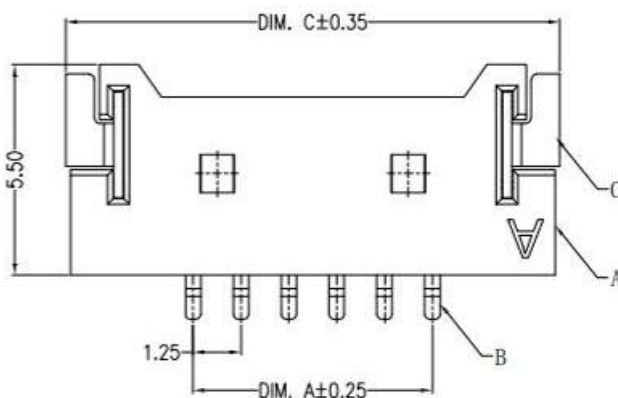
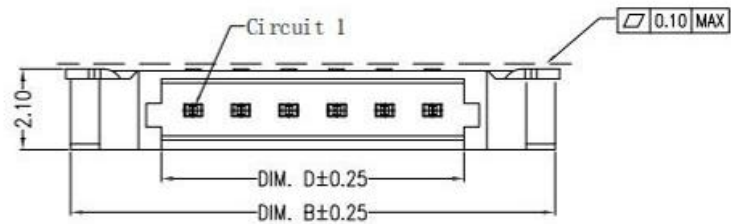
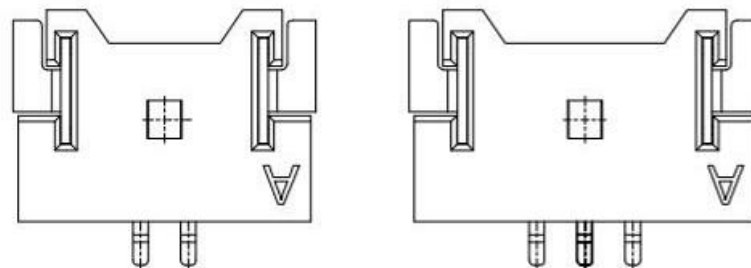

Main Specifications

- Poles: 02 to 15
- Contact resistance: $\leq 20m \Omega$
- Insulation resistance: $\geq 100M \Omega$
- Rated voltage: 125V AC DC
- Rated current: 1.0A AC DC
- Withstand Voltage: 500V AC/minute
- Temperature Range: $-25^{\circ}C \sim +85^{\circ}C$

ORDER INFORMATION:

PART No.	_____	PACKAGING:	_____
No. OF CIRCUITS:	02~30	3-TRIAL	_____
PLASTIC MATERIAL:	P1C-LCP (BEIGE)	P-PS	_____
	FIX-LCP (BLACK)	Metal code:	1=PhosphorBronze
		PLATING:	C-GOLD

Circuits	Dimensions(mm)			
	DIM. A	DIM. B	DIM. C	DIM. D
02	1.25	7.65	7.90	2.90
03	2.50	8.90	9.15	4.15
04	3.75	10.15	10.40	5.40
05	5.00	11.40	11.65	6.65
06	6.25	12.65	12.90	7.90
07	7.50	13.90	14.15	9.15
08	8.75	15.15	15.40	10.40
09	10.00	16.40	16.65	11.65
10	11.25	17.65	17.90	12.90
11	12.50	18.90	19.15	14.15
12	13.75	20.15	20.40	15.40
13	15.00	21.40	21.65	16.65
14	16.25	22.65	22.90	17.9
15	17.50	23.90	24.15	19.15

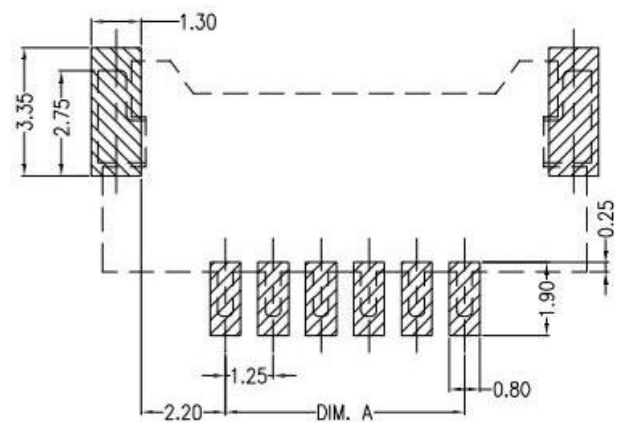

SUGGESTED PCB LAYOUT
(COMPONENT SIDE)

STANDARD TOLERANCE (EXCEPT SPECIFIED)	
LINER	ANGLES
.0 ±0.30	0.° ±5°
.00 ±0.25	.0° ±2°
.000 ±0.10	.00° ±1°

ITEM	COMPONENT	Q'TY	MATERIAL	FINISH
C	Solder Tab	1 PCS	PhosphorBronze	Gold-plated
B	Contacts	2~30PCS	PhosphorBronze	Gold-plated
A	HOUSING	2~30PIN	LCP	UL 94V-0, COLOR:BEIGE/BLACK

广东科斯达开关厂

TITLE	1.25mm Pitch 90° Wafer SMT TYPE	DRAWN BY	LZM	11/28-'19
PART NO.		CHECKED BY		
DRAWING NO.		APPROVED BY		
SCALE	1:1	UNIT	mm	PAGE 1/1
				SIZE A4

REV	ECN NO	DESCRIPTION	DATE	NAME
A	—	NEW	11/28-'19	LZM

RoHS

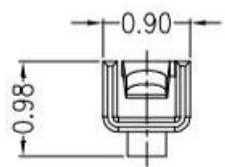
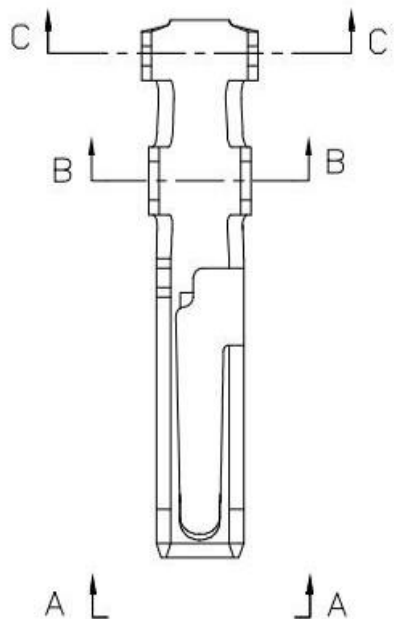
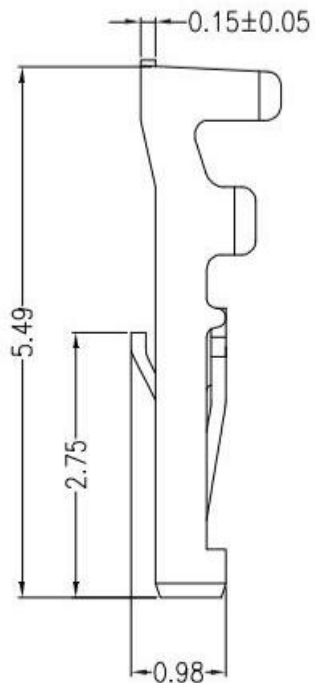

A-A

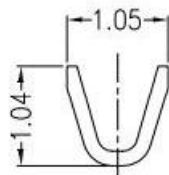

B-B

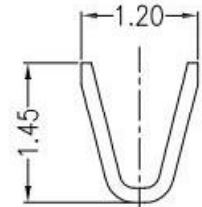
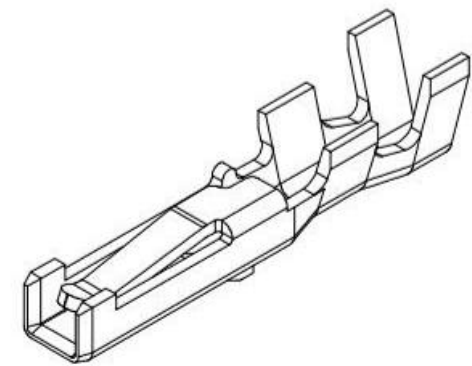

C-C

C				
B				
A	CONTACT	1 PCS	Phosphor bronze	Sn-plated
ITEM	COMPONENT	Q'TY	MATERIAL	FINISH

广东科斯达开关厂

Ordering Information & Specification:

Part No	Wire Range	Insulation O. D.	Material	Finish	Qty/Reel
L1254T-PA-Z	AWG #28~32	0.90mm(max)	Phosphor bronze	Sn-plated	10,000 pcs

STANDARD TOLERANCE (EXCEPT SPECIFIED)	
LINER	ANGLES
.0 ±0.30	0.° ±5°
.00 ±0.25	.0° ±2°
.000 ±0.10	.00° ±1°

TITLE		DRAWN BY	LZM	11/28-'19
PART NO.		CHECKED BY		
DRAWING NO.		APPROVED BY		
SCALE	1:1	UNIT	mm	
PAGE	1/1	SIZE	A4	