

RoHS

REV	ECN NO	DESCRIPTION	DATE	NAME
A	—	NEW	11/21-'19	XXL

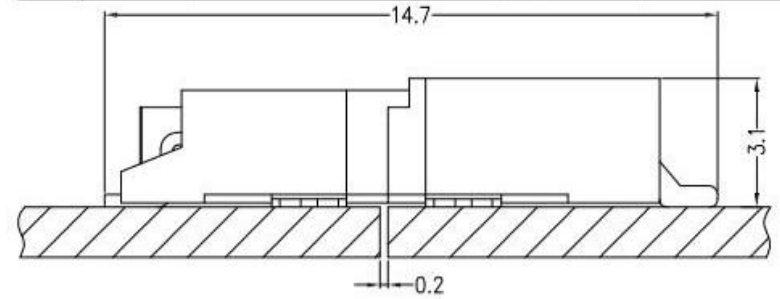
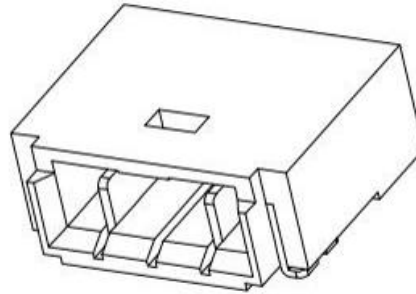
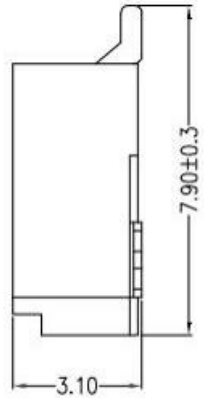
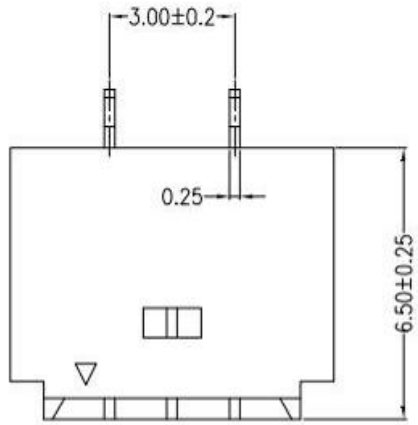

Assembly Layout

Main Specifications:

- 1.Poles:02p
- 2.Contact Resistance:20 mΩ max.
- 3.Insulator Resistance:1000 Megohms min.
- 4.Rated voltage:150v AC DC
- 5.Rated current:1.0A AC DC
- 6.Dielectric withstanding Voltage: AC 1000V/minute
- 7.-25°C to+105°C

Ordering Information

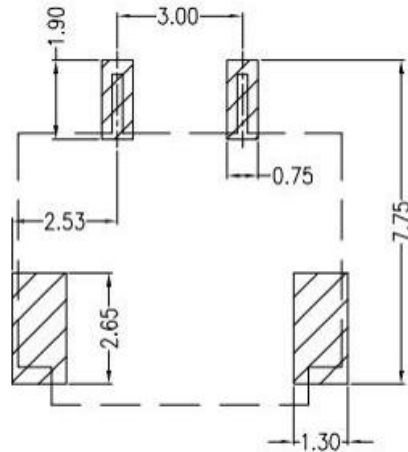
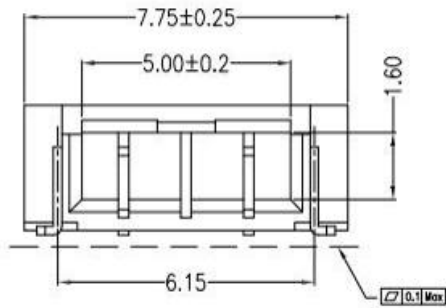
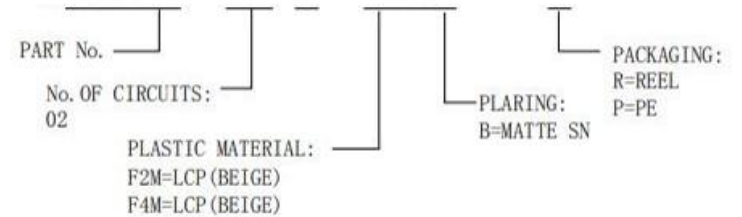

Board Layout

General Tolerance: ± 0.05

STANDARD TOLERANCE (EXCEPT SPECIFIED)

LINER	ANGLES
.0 ±0.30	0.° ±3°
.00 ±0.20	.0° ±2°
.000 ±0.10	.00° ±1°

广东科斯达开关厂

TITLE	3.0MM PITCH 1X2P 90° WAFER SMT TYPE	DRAWN BY	XXL	DATE	11/21-'19
PART NO.		CHECKED BY			
DRAWING NO.		APPROVED BY			
SCALE	1:1	UNIT	mm	PAGE	1/1
SIZE	A4				