

RoHS

REV	ECN NO	DESCRIPTION	DATE	NAME
A		NEW		

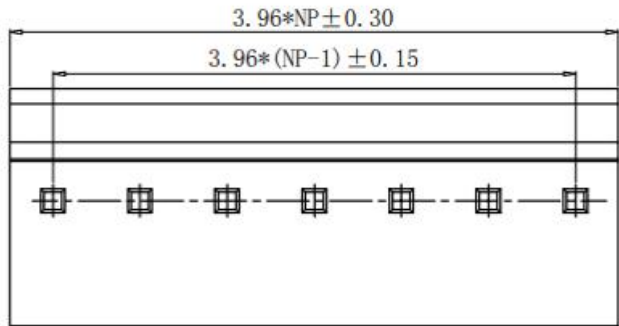

Note:

1.Material

- 1.1: Housing: NY66, Color:White
- 1.2: Contact: Brass,Tin.

2.Rating:

- 2.1: Operating Voltage: 250V AC/DC.
- 2.2: Current Rating: 6A AC/DC.
- 2.3: Operating Temperature:-25°C~+85°C.
- 2.4: Contact Resistance:30 mΩ max.
- 2.5: nsulation Resistance:1000 MΩ min.
- 2.6: Dielectric withstanding Voltage: AC 1500V

3.Pater Number:

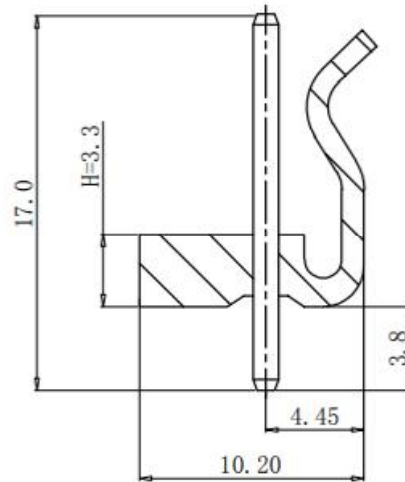
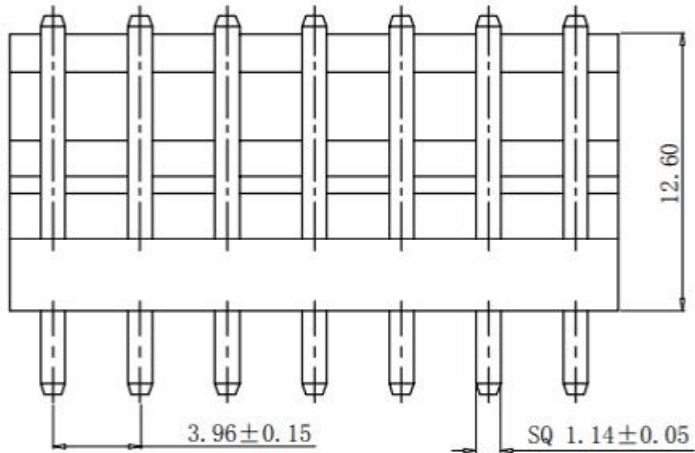

Ordering Information

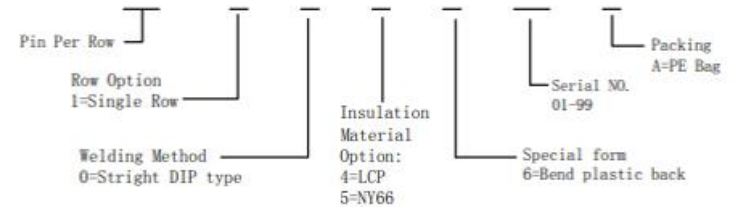

PCB LAYOUT

广东科斯达开关厂

STANDARD TOLERANCE (EXCEPT SPECIFIED)

LINER	ANGLES
.0 ±0.30	0.° ±3°
.00 ±0.20	.0° ±2°
.000 ±0.10	.00° ±1°

TITLE		PH3.96mm Wafer Single row, DIP straight type with Bend plastic back		DRAWN BY		WZG		17.03.30	
PART NO				CHECKED BY					
DRAWING NO				APPROVED BY					
SCALE	1:1	UNIT	mm	PAGE	1/1	SIZE	A4		