

RoHS

REV	ECN NO	DESCRIPTION	DATE	NAME
A	—	NEW	11/21-'19	XXL

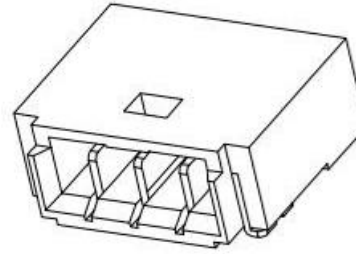
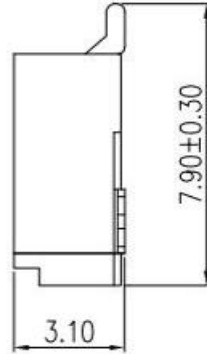
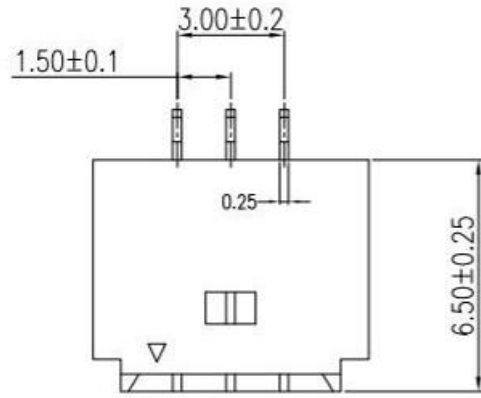

Main Specifications:

- 1.Poles:03p
- 2.Contact Resistance:20 mΩ max.
- 3.Insulator Resistance:1000 Megohms min.
- 4.Rated voltage:150v AC DC
- 5.Rated current:1.0A AC DC
- 6.Dielectric withstanding Voltage: AC 1000V/minute
- 7.-25°C to+105°C

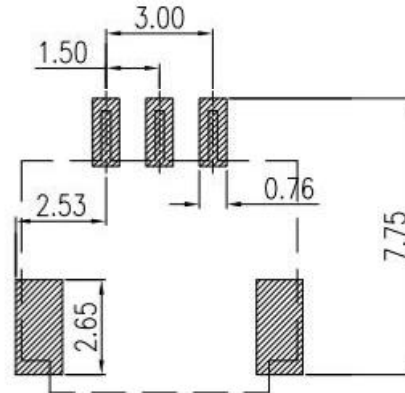
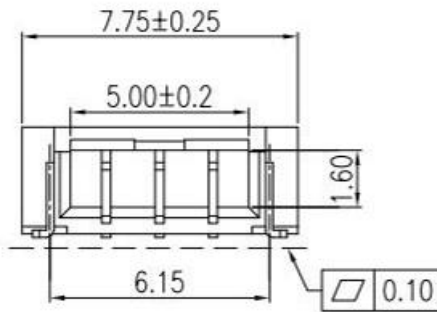

Ordering Information

L1504R -XX = XXXB - R

PART No. ————

No. OF CIRCUITS: 03

PLASTIC MATERIAL:
F2M=LCP (BEIGE)
F4M=LCP (BEIGE)

PACKAGING:
R=REEL
P=PE

PLATING:
B=MATTE SN

Board Layout
General Tolerance: ±0.05

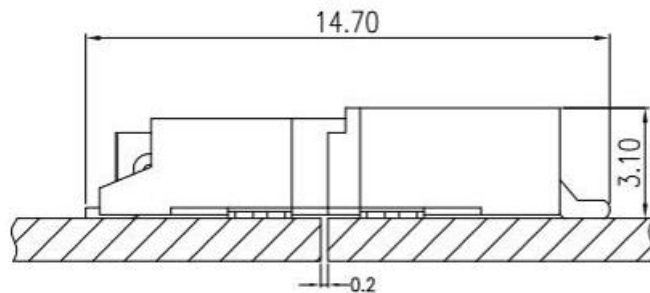

Assembly Layout

STANDARD TOLERANCE (EXCEPT SPECIFIED)	
LINER	ANGLES
.0 ±0.30	0.° ±3°
.00 ±0.20	.0° ±2°
.000 ±0.10	.00° ±1°

广东科斯达开关厂									
TITLE	1.50mm 03P 90° WAFER SMT TYPE		DRAWN BY		XXL	11/21-'19			
PART NO.			CHECKED BY						
DRAWING NO.			APPROVED BY						
SCALE	1:1	UNIT	mm		PAGE	1/1	SIZE	A4	