

RoHS Compliant

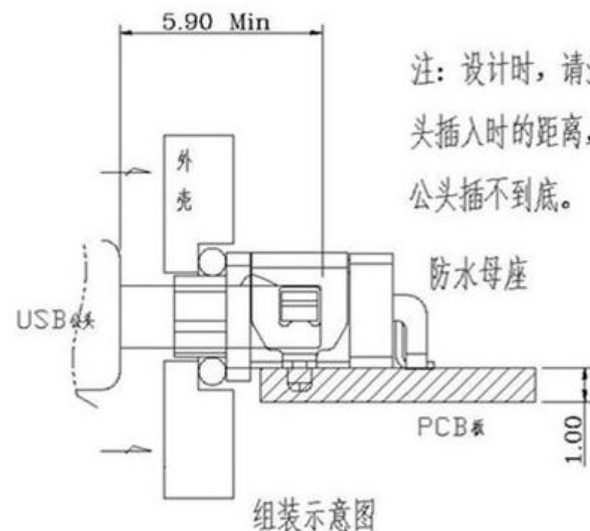

注: 设计时, 请注意公头插入时的距离, 防止公头插不到位。

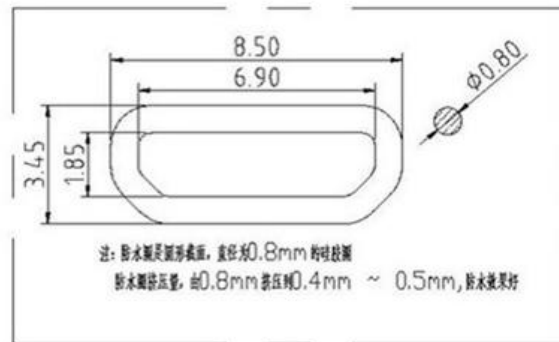
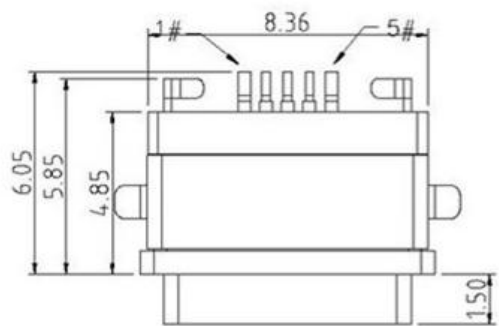
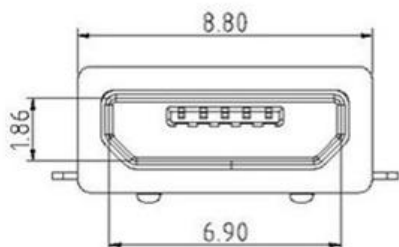
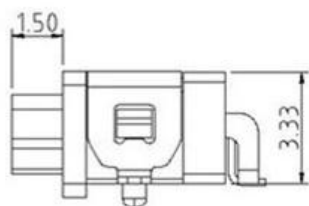
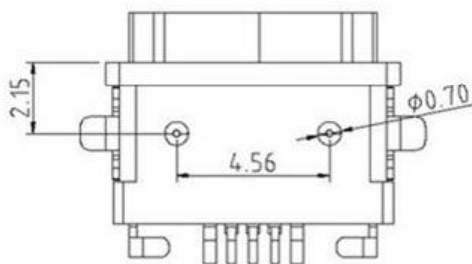

NOTES:

SPECIFICATION:

1. CURRENT RATING: 3.0A MAX
2. DIELECTRIC WITHSTAND VOLTAGE: 100VAC
3. TEMPERATURE RANGE:  $-30\text{ }^{\circ}\text{C} \sim 85\text{ }^{\circ}\text{C}$
4. CONTACT RESISTANCE: 40 MILLIONHM MAX
5. INSULATION RESISTANCE: 100 MEGOHMS MIN.
6. INSERTION FORCE :8N~35N
7. UNMATING FORCE: 8N~35N
8. DURABILITY:1500 CYCLES

|   |            |   |                 |               |          |
|---|------------|---|-----------------|---------------|----------|
| ⑤ | MID PLATE  | 1 | STAINLESS STEEL | Au . PLATING. | T=0.15mm |
| ④ | SHELL      | 1 | STAINLESS STEEL | Au . PLATING. | T=0.30mm |
| ③ | TERMINAL-B | 1 | TABLE 2:        | TABLE 2:      | T=0.12mm |
| ② | TERMINAL-A | 1 | TABLE 2:        | TABLE 2:      | T=0.12mm |
| ① | INSULATOR  | 1 | HIGH TEMP       | Black         |          |

| NO. | PART NAME | QTY | MATERIAL | DESCRIPTION | REMARK |
|-----|-----------|-----|----------|-------------|--------|
|-----|-----------|-----|----------|-------------|--------|

UNLESS OTHERWISE SPECIFIED, GENERAL TOLERANCE:  
 X.xxx ±0.10  
 X.xx ±0.20  
 X.x ±0.30  
 X. ±0.38  
 ANGULAR:  
 X.xx ±1°  
 X.x ±3°  
 X. ±5°

# 广东科斯达开关厂

|                        |                               |        |       |        |
|------------------------|-------------------------------|--------|-------|--------|
| TITLE:                 | P/N: Detail See PART NO. LIST |        |       |        |
| USB connector          | MODEL:                        |        |       |        |
| DRAW NO.:              |                               |        |       |        |
| THIRD ANGLE PROJECTION | UNIT:                         | SCALE: | SIZE: | SHEET: |
|                        | mm                            | 1:1    | A4    | 1/1    |

|             |      |             |            |        |          |     |            |  |
|-------------|------|-------------|------------|--------|----------|-----|------------|--|
| JH2016-080  | X2   | 随工程图上升版本次   | 2016.06.15 | 陈少兵    | DESIGN   | 陈少兵 | 2016.06.15 |  |
| JH2016-071  | X1   | 新增规格        | 2016.06.10 | 陈少兵    | CHECK    | 郑小伟 | 2016.06.15 |  |
| 20151224001 | X    | NEW DRAWING | 2016.05.05 | 陈少兵    | APPROVAL | 吕海涛 | 2016.06.15 |  |
| ECN NO.     | REV. | DESCRIPTION | DATE       | CHANGE |          |     |            |  |