

RoHS Compliant

NOTES:

1. ELECTRICAL:
 - 1) VOLTAGE CURRENT RATING: 1AMP, 30V AC;
 - 2) INSULATION RESISTANCE: 100MΩ MIN;
 - 3) CONTACT RESISTANCE: 30mΩ MAX;
 - 4) WITHSTANDING VOLTAGE: 500V AC;
 - 5) OPERATING TEMPERATURE: -40°C TO +85°C.
2. Mechanical:
 - 1) Mating Force: 35N MAX
 - 2) Unmating Force: 10N MIN.
3. DIMENSIONS MARKED "▼" TO BE CHECKED BY Q.C & IPQC.
4. PART NO.

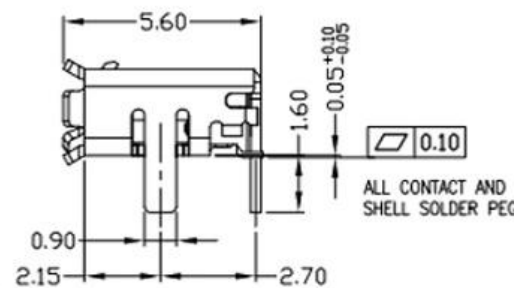
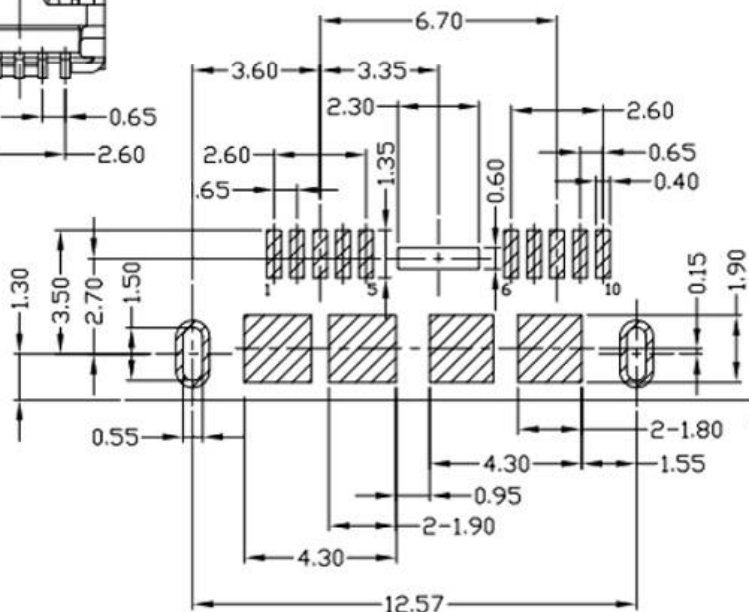
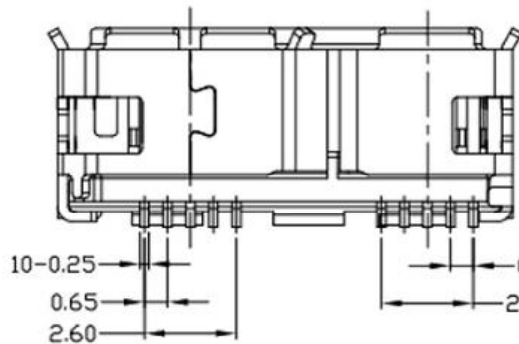
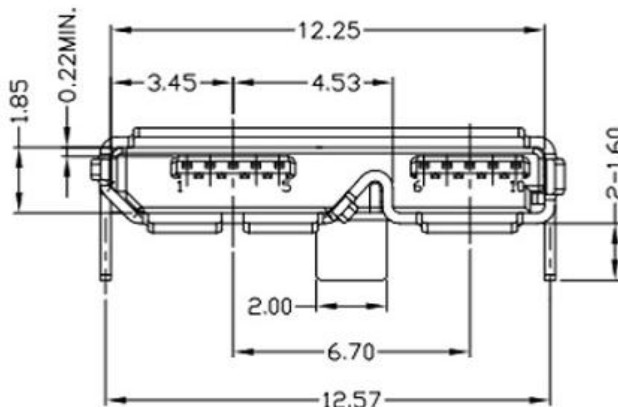
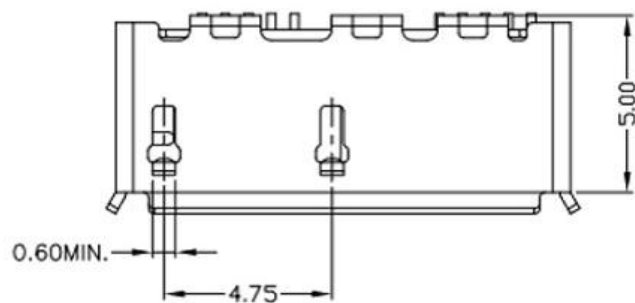

1: Au 1U*
5: Au 15U*
6: Au 30U*

W: WHITE
B: BLACK

1PBT
2PA6T
3PA9T
4LCP

PIN NUMBER	SIGNAL NAME
1	VBUS
2	D-
3	D+
4	ID
5	GND
6	MICB_SSTX-
7	MICB_SSTX+
8	GND_DRAIN
9	MICB_SSRX-
10	MICB_SSRX+
Shell	Shield

RECOMMENDED P.C.B LAYOUT

NO.	PART NAME	QTY	MATERIAL	DESCRIPTION	REMARK
⑤	MID PLATE	1	STAINLESS STEEL	Au . PLATING.	T=0.15mm
④	SHELL	1	STAINLESS STEEL	Au . PLATING.	T=0.30mm
③	TERMINAL-B	1	TABLE 2:	TABLE 2:	T=0.12mm
②	TERMINAL-A	1	TABLE 2:	TABLE 2:	T=0.12mm
①	INSULATOR	1	HIGH TEMP	Black	

UNLESS OTHERWISE SPECIFIED, GENERAL TOLERANCE:

X.xxx ±0.10
X.xx ±0.20
X.x ±0.30
X. ±0.38

ANGULAR:

X.xx ±1°
X.x ±3°
X. ±5°

广东科斯达开关厂

TITLE:	USB connector				P/N: Detail See PART NO. LIST
MODEL:					DRAW NO.:
THIRD ANGLE PROJECTION	UNIT:	SCALE:	SIZE:	SHEET:	
	mm	1:1	A4	1/1	

ECN NO.	REV.	DESCRIPTION	DATE	CHANGE	APPROVAL	DATE
JH2016-080	X2	随工程图上升版本次	2016.06.15	陈少兵	DESIGN	2016.06.15
JH2016-071	X1	新增规格	2016.06.10	陈少兵	CHECK	2016.06.15
20151224001	X	NEW DRAWING	2016.05.05	陈少兵	APPROVAL	2016.06.15