

RoHS Compliant

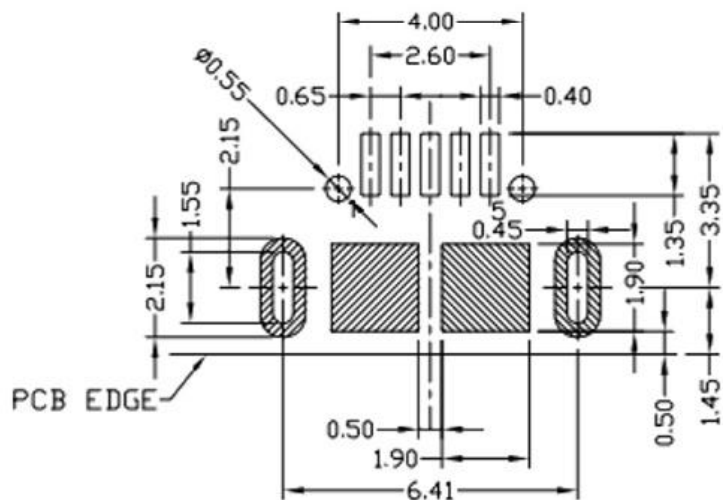
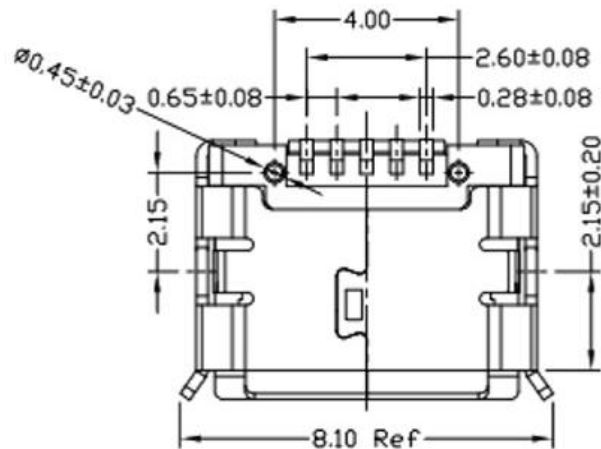
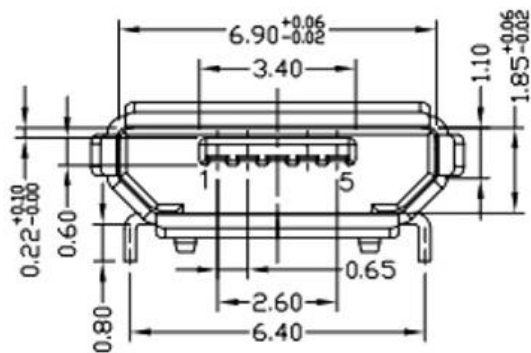
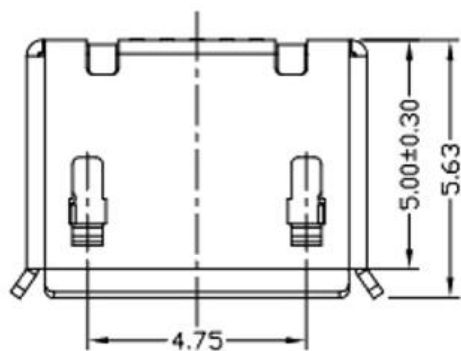
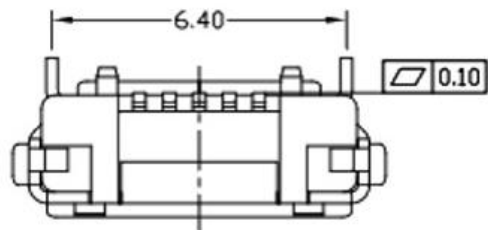

RECOMMENDED PCB LAYOUT

NOTES:

1.ELECTRICAL:

- 1) VOLTAGE CURRENT RATING: PIN1&5 1.8AMP MAX / PIN2&3&4 1AMP MAX. ,30V AC;
- 2) INSULATION RESISTANCE: 100MΩ MIN;
- 3) CONTACT RESISTANCE: 30mΩ MAX;
- 4) WITHSTANDING VOLTAGE: 100V AC; FOR 1 MIN.
- 5) OPERATING TEMPERATURE: -30°C TO +80°C.

2.Mechanical:

- 1) Mating Force: 35N MAX
- 2) Unmating Force: 10N MIN.

3. DIMENSIONS MARKED '▼' TO BE CHECKED BY Q.C & IPQC.

4.PART NO.

| | |
|------------|----------|
| 1: Au 1U* | W: WHITE |
| 6: Au 30U* | B: BLACK |
| T: TIN | 1: PBT |
| N: NICKEL | 2: PA6T |
| | 3: PA9T |
| | 4: LCP |

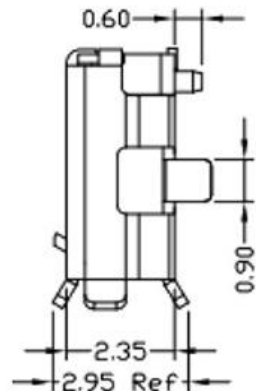

| | | | | | |
|---|------------|---|-----------------|---------------|----------|
| ⑤ | MID PLATE | 1 | STAINLESS STEEL | Au . PLATING. | T=0.15mm |
| ④ | SHELL | 1 | STAINLESS STEEL | Au . PLATING. | T=0.30mm |
| ③ | TERMINAL-B | 1 | TABLE 2: | TABLE 2: | T=0.12mm |
| ② | TERMINAL-A | 1 | TABLE 2: | TABLE 2: | T=0.12mm |
| ① | INSULATOR | 1 | HIGH TEMP | Black | |

| NO. | PART NAME | QTY | MATERIAL | DESCRIPTION | REMARK |
|-----|-----------|-----|----------|-------------|--------|
|-----|-----------|-----|----------|-------------|--------|

UNLESS OTHERWISE, GENERAL TOLERANCE:

| | |
|-------|-------|
| X.xxx | ±0.10 |
| X.xx | ±0.20 |
| X.x | ±0.30 |
| X. | ±0.38 |

ANGULAR:

| | |
|------|-----|
| X.xx | ±1° |
| X.x | ±3° |
| X. | ±5° |

广东科斯达开关厂

| | | | | |
|------------------------|-------------------------------|--------|-------|--------|
| TITLE: | P/N: Detail See PART NO. LIST | | | |
| USB connector | MODEL: | | | |
| | DRAW NO.: | | | |
| THIRD ANGLE PROJECTION | UNIT: | SCALE: | SIZE: | SHEET: |
| | mm | 1:1 | A4 | 1/1 |

| | | | | | | | |
|-------------|------|-------------|------------|--------|----------|-----|------------|
| JH2016-080 | X2 | 随工程图上升版本次 | 2016.06.15 | 陈少兵 | DESIGN | 陈少兵 | 2016.06.15 |
| JH2016-071 | X1 | 新增规格 | 2016.06.10 | 陈少兵 | CHECK | 郑小伟 | 2016.06.15 |
| 20151224001 | X | NEW DRAWING | 2016.05.05 | 陈少兵 | APPROVAL | 吕海涛 | 2016.06.15 |
| ECN NO. | REV. | DESCRIPTION | DATE | CHANGE | | | |