

RoHS Compliant

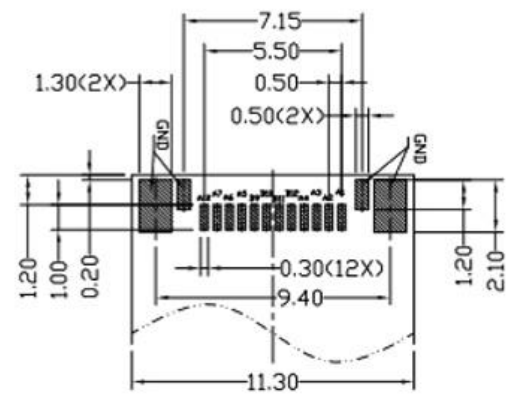
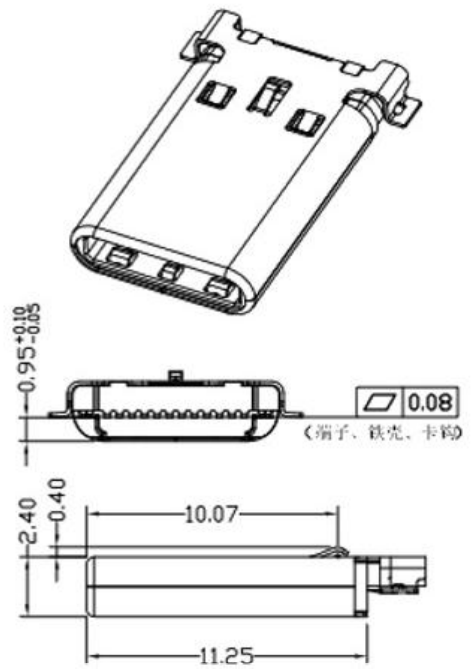
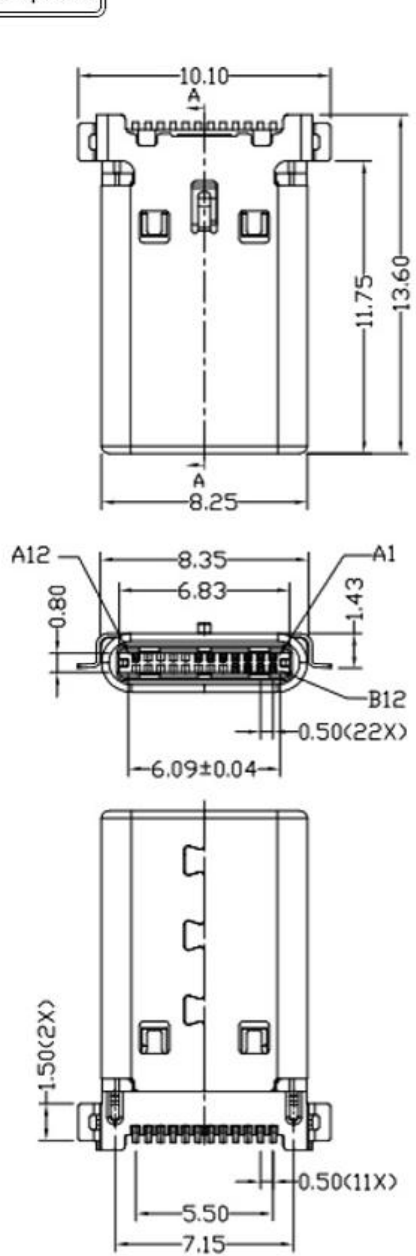

RECOMMENDED PCB LAYOUT(TOP VIEW)
TOLERANCE:±0.05

NOTES:

1.ELECTRICAL:

- 1) VOLTAGE CURRENT RATING: 5AMP 5.0VDC
- 2) INSULATION RESISTANCE: 100MΩ MIN 250V DC;
- 3) CONTACT RESISTANCE: 40mΩ MAX;
- 4) WITHSTANDING VOLTAGE: 100V AC FOR 1 MINUTE.
- 5) OPERATING TEMPERATURE: -25°C TO +85°C.

2.Mechanical:

- 1) Mating Force: 5N~20N
- 2) Unmating Force: 8N~20N
- 3) Durability: 10,000 cycles

3.DIMENSIONS MARKED '▼'

TO BE CHECKED BY Q.C & IPQC.

4.PART NO.



USB TYPE-C PIN ASSIGNMENTS

PIN NUMBER	SIGNAL NAME	PIN NUMBER	SIGNAL NAME
A1	GND	B12	GND
A2	SSTXp1	B11	SSRXp1
A3	SSTXn1	B10	SSRXn1
A4	Vbus	B9	Vbus
A5	CC1	B8	
A6	Dp1	B7	
A7	Dn1	B6	
A8		B5	
A9		B4	
A10		B3	
A11		B2	
A12	GND	B1	

⑤ MID PLATE	1	STAINLESS STEEL	Au . PLATING.	T=0.15mm
④ SHELL	1	STAINLESS STEEL	Au . PLATING.	T=0.30mm
③ TERMINAL-B	1	TABLE 2:	TABLE 2:	T=0.12mm
② TERMINAL-A	1	TABLE 2:	TABLE 2:	T=0.12mm
① INSULATOR	1	HIGH TEMP	Black	

NO.	PART NAME	QTY	MATERIAL	DESCRIPTION	REMARK
-----	-----------	-----	----------	-------------	--------

UNLESS OTHERWISE,
GENERAL TOLERANCE:
X.xxx ±0.10
X.xx ±0.20
X.x ±0.30
X. ±0.38
ANGULAR:
X.xx ±1°
X.x ±3°
X. ±5°

广东科斯达开关厂

TITLE:	USB connector				P/N: Detail See PART NO. LIST
	DRAW NO.:				
THIRD ANGLE PROJECTION	UNIT:	SCALE:	SIZE:	SHEET:	
	mm	1:1	A4	1/1	

ECN NO.	REV.	DESCRIPTION	DATE	CHANGE	APPROVAL	DATE
JH2016-080	X2	随工程图上升版本次	2016.06.15	陈少兵	DESIGN	陈少兵 2016.06.15
JH2016-071	X1	新增规格	2016.06.10	陈少兵	CHECK	郑小伟 2016.06.15
20151224001	X	NEW DRAWING	2016.05.05	陈少兵	APPROVAL	吕海涛 2016.06.15