

NOTES:
 1.ELECTRICAL:
 1)VOLTAGE CURRENT RATING:2AMP,30V DC;
 2)INSULATION RESISTANCE: 1000MΩ MIN;
 3)CONTACT RESISTANCE: 30mΩ MAX;
 4)WITHSTANDING VOLTAGE: 500V AC FOR 1MIN;
 5)OPERATING TEMPERATURE:-30°C TO +85°C.
 2.Mechanical:
 1)Mating Force: 35N MAX
 2)Unmating Force: 10N MIN.
 3.DIMENSIONS MARKED "▼"
 TO BE CHECKED BY Q.C & IPQC.
 4. PART NO.

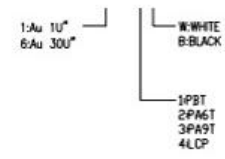
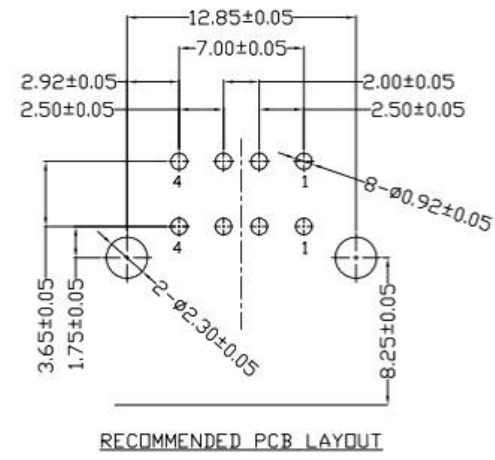
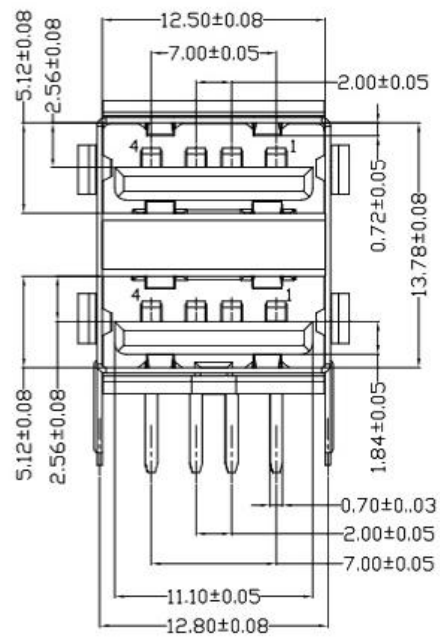
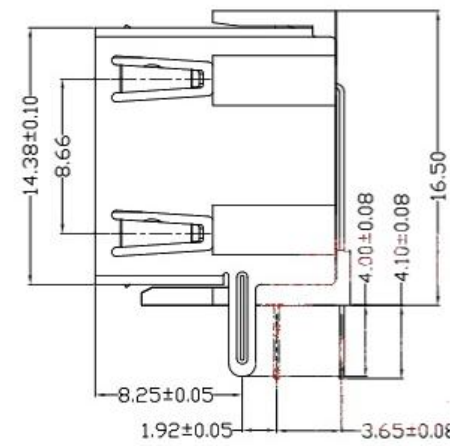
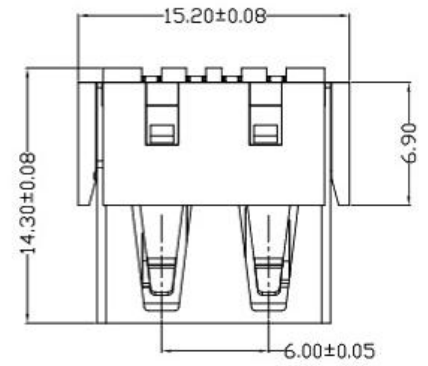

⑤	MID PLATE	1	STAINLESS STEEL	Au . PLATING.	T=0.15mm
④	SHELL	1	STAINLESS STEEL	Au . PLATING.	T=0.30mm
③	TERMINAL-B	1	TABLE 2:	TABLE 2:	T=0.12mm
②	TERMINAL-A	1	TABLE 2:	TABLE 2:	T=0.12mm
①	INSULATOR	1	HIGH TEMP	Black	
NO.	PART NAME	QTY	MATERIAL	DESCRIPTION	REMARK

UNLESS OTHERWISE,
 GENERAL TOLERANCE:
 X.xxx ±0.10
 X.xx ±0.20
 X.x ±0.30
 X. ±0.38
 ANGULAR:
 X.xx ±1°
 X.x ±3°
 X. ±5°

广东科斯达开关厂

TITLE: USB connector

P/N: Detail See PART NO. LIST

MODEL:

DRAW NO.:

THIRD ANGLE PROJECTION	UNIT: mm	SCALE: 1:1	SIZE: A4	SHEET: 1/1
------------------------	----------	------------	----------	------------

JH2016-080	X2	随工程图上升版本次	2016.06.15	陈少兵	DESIGN	陈少兵	2016.06.15
JH2016-071	X1	新增规格	2016.06.10	陈少兵	CHECK	郑小伟	2016.06.15
20151224001	X	NEW DRAWING	2016.05.05	陈少兵	APPROVAL	吕海涛	2016.06.15
ECN NO.	REV.	DESCRIPTION	DATE	CHANGE			