

RoHS Compliant

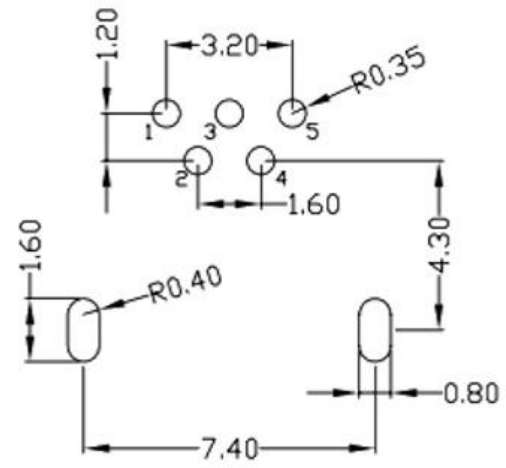
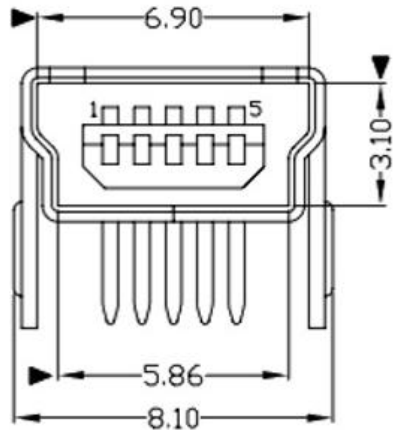
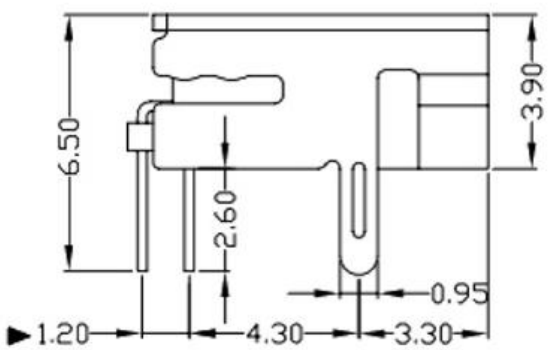
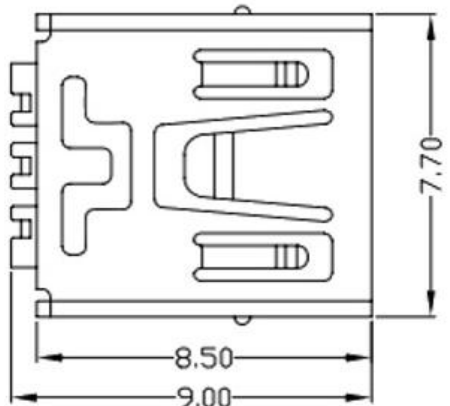
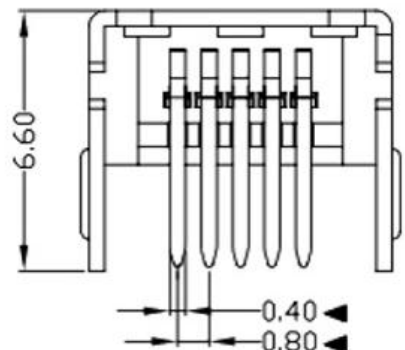

RECOMMENDED PCB LAYOUT

NOTES:

1. ELECTRICAL:
 - 1) VOLTAGE CURRENT RATING: 1.0AMP,30V AC;
 - 2) INSULATION RESISTANCE: 100MΩ MIN;
 - 3) CONTACT RESISTANCE: 50mΩ MAX;
 - 4) WITHSTANDING VOLTAGE: 300V AC;
 - 5) OPERATING TEMPERATURE:-55°C TO +85°C.
2. Mechanical:
 - 1) Mating Force: 30N MAX
 - 2) Unmating Force: 7N MIN.
3. DIMENSIONS MARKED "▼" TO BE CHECKED BY Q.C & IPQC.
- 4.PART NO.

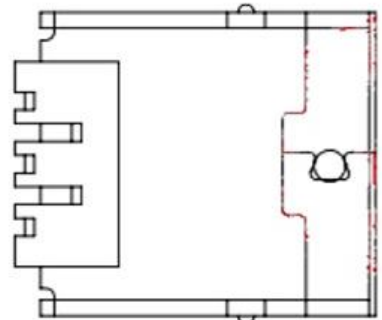

⑤	MID PLATE	1	STAINLESS STEEL	Au . PLATING.	T=0.15mm
④	SHELL	1	STAINLESS STEEL	Au . PLATING.	T=0.30mm
③	TERMINAL-B	1	TABLE 2:	TABLE 2:	T=0.12mm
②	TERMINAL-A	1	TABLE 2:	TABLE 2:	T=0.12mm
①	INSULATOR	1	HIGH TEMP	Black	
NO.	PART NAME	QTY	MATERIAL	DESCRIPTION	REMARK

UNLESS OTHERWISE,
GENERAL TOLERANCE:
X.xxx ±0.10
X.xx ±0.20
X.x ±0.30
X. ±0.38
ANGULAR:
X.xx ±1°
X.x ±3°
X. ±5°

广东科斯达开关厂

TITLE: USB connector		P/N: Detail See PART NO. LIST		
THIRD ANGLE PROJECTION		DRAW NO.:		
UNIT: mm	SCALE: 1:1	SIZE: A4	SHEET: 1/1	

JH2016-080	X2	随工程图上升版本次	2016.06.15	陈少兵	DESIGN	陈少兵	2016.06.15
JH2016-071	X1	新增规格	2016.06.10	陈少兵	CHECK	郑小伟	2016.06.15
20151224001	X	NEW DRAWING	2016.05.05	陈少兵	APPROVAL	吕海涛	2016.06.15
ECN NO.	REV.	DESCRIPTION	DATE	CHANGE			