

NOTES:  
 1. ELECTRICAL:  
 1) VOLTAGE CURRENT RATING: 2AMP, 30V AC;  
 2) INSULATION RESISTANCE: 1000MΩ MIN;  
 3) CONTACT RESISTANCE: 30mΩ MAX;  
 4) WITHSTANDING VOLTAGE: 500V AC;  
 5) OPERATING TEMPERATURE: -55°C TO +85°C.  
 2. Mechanical:  
 1) Mating Force: 35N MAX  
 2) Unmating Force: 10N MIN.  
 3. NOTE: 1. DIMENSIONS MARKED "▼" TO BE CHECKED BY Q.C & IPQC.  
 4. PART NO.

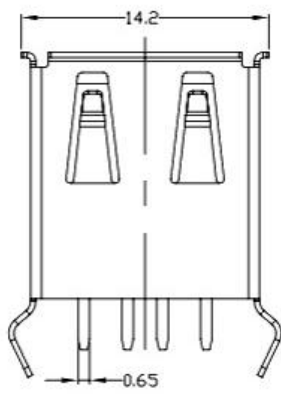

1/Au 1U"  
 6/Au 30U"  
 W/WHITE  
 B/BLACK  
 1/PBT  
 2/PA6T  
 3/PA9T  
 4/LCP

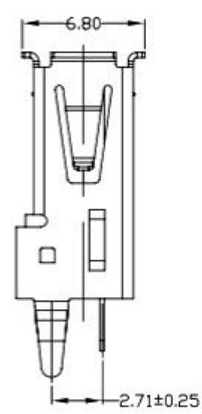
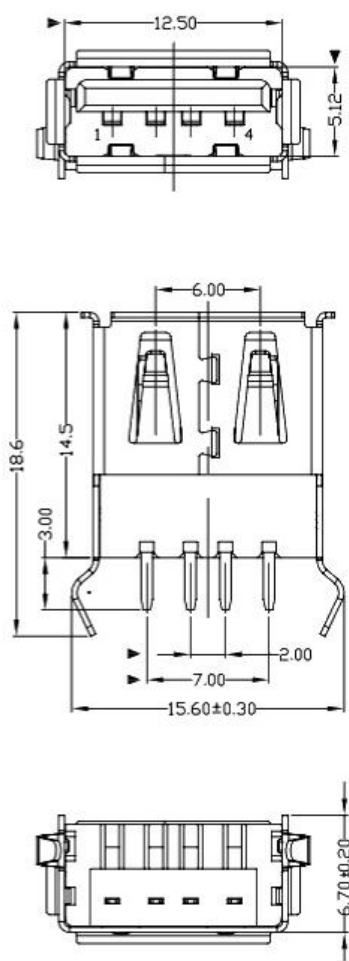
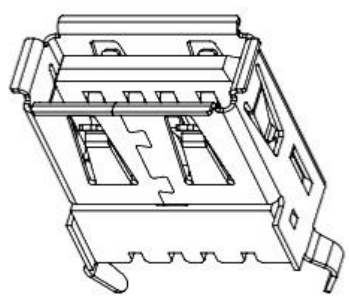
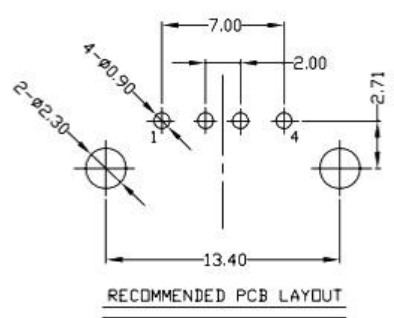

⑤	MID PLATE	1	STAINLESS STEEL	Au . PLATING.	T=0.15mm
④	SHELL	1	STAINLESS STEEL	Au . PLATING.	T=0.30mm
③	TERMINAL-B	1	TABLE 2:	TABLE 2:	T=0.12mm
②	TERMINAL-A	1	TABLE 2:	TABLE 2:	T=0.12mm
①	INSULATOR	1	HIGH TEMP	Black	
NO.	PART NAME	QTY	MATERIAL	DESCRIPTION	REMARK

UNLESS OTHERWISE,  
 GENERAL TOLERANCE:  
 X.xxx ±0.10  
 X.xx ±0.20  
 X.x ±0.30  
 X. ±0.38  
 ANGULAR:  
 X.xx ±1°  
 X.x ±3°  
 X. ±5°

# 广东科斯达开关厂

TITLE: USB connector		P/N: Detail See PART NO. LIST		
THIRD ANGLE PROJECTION		DRAW NO.:		
UNIT: mm	SCALE: 1:1	SIZE: A4	SHEET: 1/1	

JH2016-080	X2	随工程图上升版本次	2016.06.15	陈少兵	DESIGN	陈少兵	2016.06.15
JH2016-071	X1	新增规格	2016.06.10	陈少兵	CHECK	郑小伟	2016.06.15
20151224001	X	NEW DRAWING	2016.05.05	陈少兵	APPROVAL	吕海涛	2016.06.15
ECN NO.	REV.	DESCRIPTION	DATE	CHANGE			