

RoHS Compliant

NOTES:

- ELECTRICAL:
  - VOLTAGE CURRENT RATING: 1.0AMP,30V AC;
  - INSULATION RESISTANCE: 100MΩ MIN;
  - CONTACT RESISTANCE: 50mΩ MAX;
  - WITHSTANDING VOLTAGE: 300V AC;
  - OPERATING TEMPERATURE: -25°C TO +85°C.
- Mechanical:
  - Mating Force: 35N MAX
  - Unmating Force: 7N MIN.
- DIMENSIONS MARKED '▽' TO BE CHECKED BY Q.C & IPQC.
- PART NO.

1:Au 1U\*  
6:Au 30U\*  
N:NICKET  
T:TIN

W:WHITE  
B:BLACK

1PBT  
2PA6T  
3PA9T  
4LCP

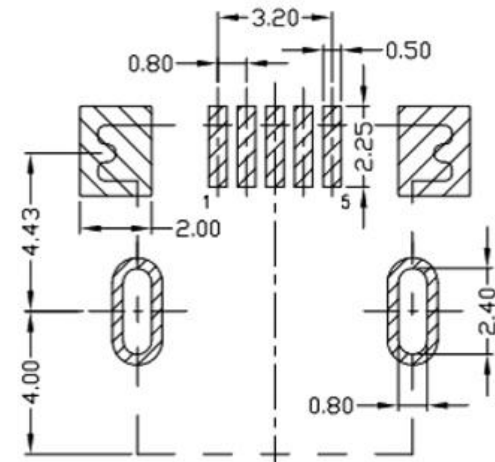
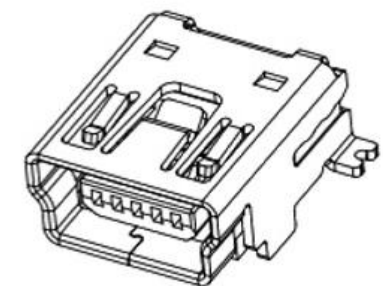
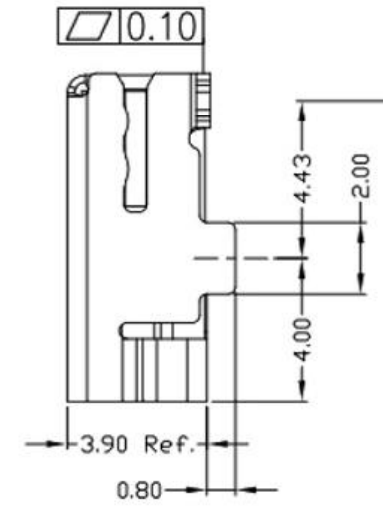
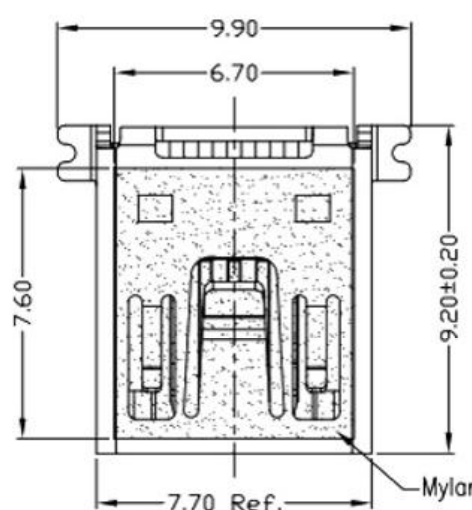
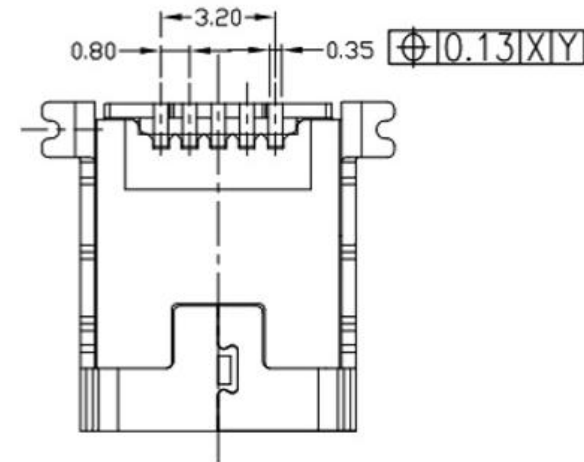
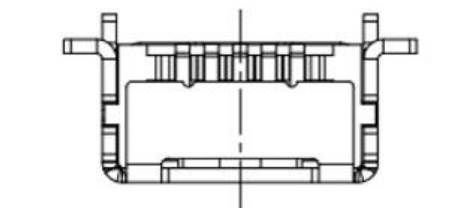

RECOMMENDED P.C.B LAYOUT

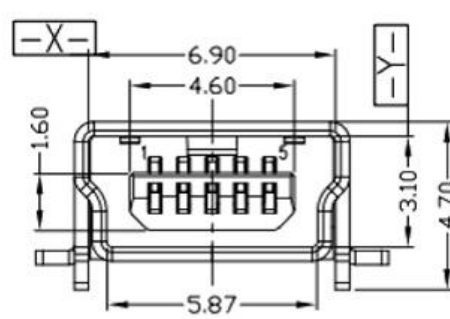

⑤	MID PLATE	1	STAINLESS STEEL	Au . PLATING.	T=0.15mm
④	SHELL	1	STAINLESS STEEL	Au . PLATING.	T=0.30mm
③	TERMINAL-B	1	TABLE 2:	TABLE 2:	T=0.12mm
②	TERMINAL-A	1	TABLE 2:	TABLE 2:	T=0.12mm
①	INSULATOR	1	HIGH TEMP	Black	
NO.	PART NAME	QTY	MATERIAL	DESCRIPTION	REMARK

UNLESS OTHERWISE, GENERAL TOLERANCE:  
 X.xxx ±0.10  
 X.xx ±0.20  
 X.x ±0.30  
 X. ±0.38

ANGULAR:  
 X.xx ±1°  
 X.x ±3°  
 X. ±5°

广东科斯达开关厂

TITLE: USB connector

P/N: Detail See PART NO. LIST

MODEL:

DRAW NO.:

THIRD ANGLE PROJECTION	UNIT: mm	SCALE: 1:1	SIZE: A4	SHEET: 1/1
------------------------	----------	------------	----------	------------

JH2016-080	X2	随工程图上升版本次	2016.06.15	陈少兵	DESIGN	陈少兵	2016.06.15
JH2016-071	X1	新增规格	2016.06.10	陈少兵	CHECK	郑小伟	2016.06.15
20151224001	X	NEW DRAWING	2016.05.05	陈少兵	APPROVAL	吕海涛	2016.06.15
ECN NO.	REV.	DESCRIPTION	DATE	CHANGE			