

RoHS Compliant

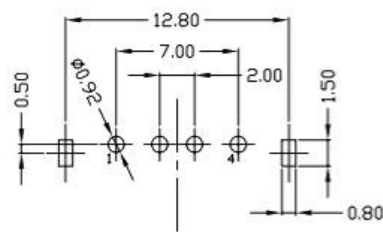
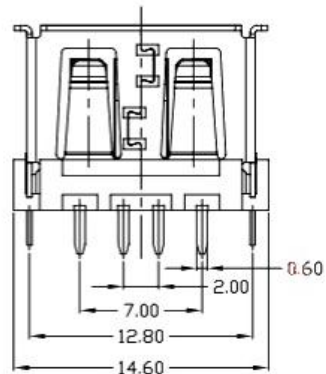
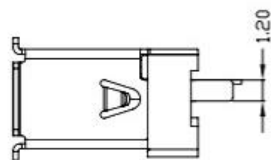
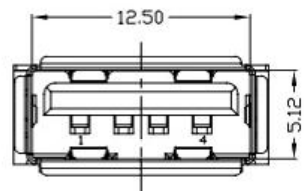
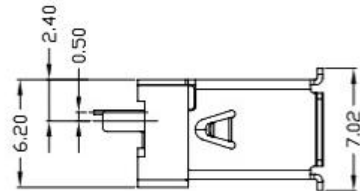
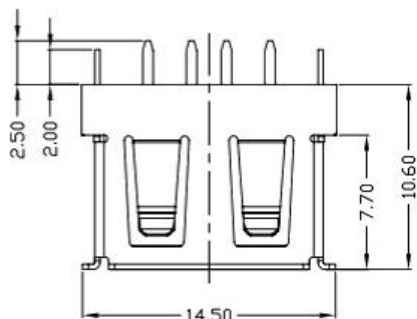

RECOMMENDED PCB LAYOUT

- NOTES:
- ELECTRICAL:
 - VOLTAGE CURRENT RATING: 2AMP, 30V AC;
 - INSULATION RESISTANCE: 1000MΩMIN;
 - CONTACT RESISTANCE: 30mΩMAX;
 - WITHSTANDING VOLTAGE: 500V AC;
 - OPERATING TEMPERATURE: -55°C TO +85°C.
 - Mechanical:
 - Mating Force: 35N MAX
 - Unmating Force: 10N MIN.
 - DIMENSIONS MARKED *▼* TO BE CHECKED BY Q.C & IPQC.
 - PART NO.

1Au 1U'
6Au 30U'

W: WHITE
B: BLACK

1PBT
2PA6T
3PA9T
4LCP

⑤	MID PLATE	1	STAINLESS STEEL	Au . PLATING.	T=0.15mm
④	SHELL	1	STAINLESS STEEL	Au . PLATING.	T=0.30mm
③	TERMINAL-B	1	TABLE 2:	TABLE 2:	T=0.12mm
②	TERMINAL-A	1	TABLE 2:	TABLE 2:	T=0.12mm
①	INSULATOR	1	HIGH TEMP	Black	

NO.	PART NAME	QTY	MATERIAL	DESCRIPTION	REMARK
UNLESS OTHERWISE, GENERAL TOLERANCE:					
			X.xxx	±0.10	
			X.xx	±0.20	
			X.x	±0.30	
			X.	±0.38	
ANGULAR:					
			X.xx	±1°	
			X.x	±3°	
			X.	±5°	

广东科斯达开关厂

TITLE:	USB connector				P/N: Detail See PART NO. LIST
					MODEL:
					DRAW NO.:
THIRD ANGLE PROJECTION	UNIT:	SCALE:	SIZE:	SHEET:	
	mm	1:1	A4	1/1	

JH2016-080	X2	随工程图上升版本次	2016.06.15	陈少兵	DESIGN	陈少兵	2016.06.15	
JH2016-071	X1	新增规格	2016.06.10	陈少兵	CHECK	郑小伟	2016.06.15	
20151224001	X	NEW DRAWING	2016.05.05	陈少兵	APPROVAL	吕海涛	2016.06.15	
ECN NO.	REV.	DESCRIPTION	DATE	CHANGE				