

RoHS Compliant

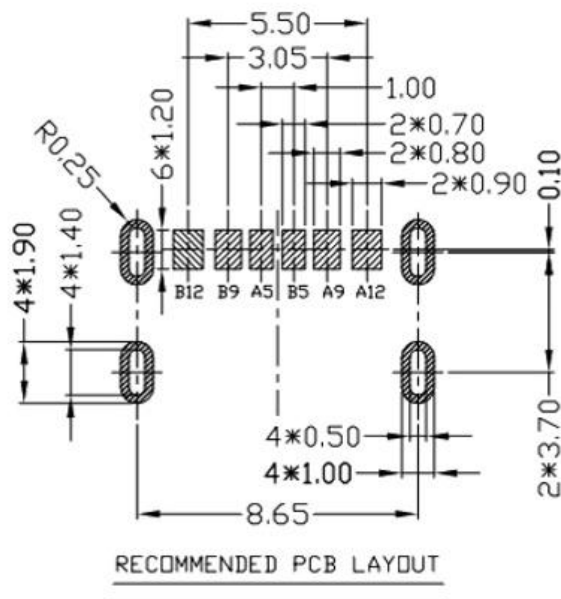
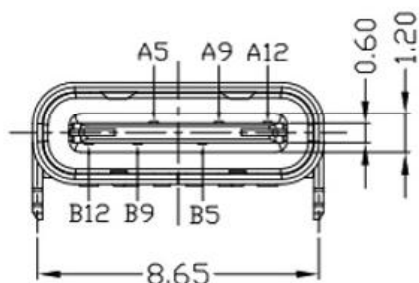
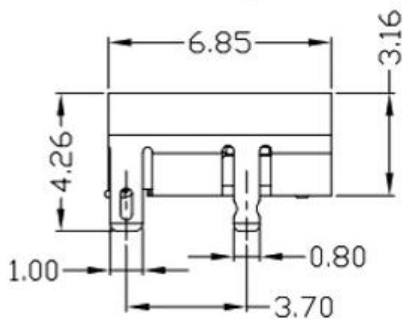
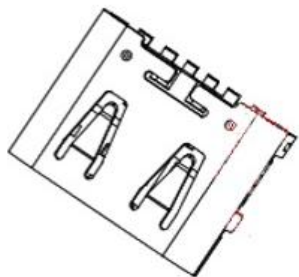
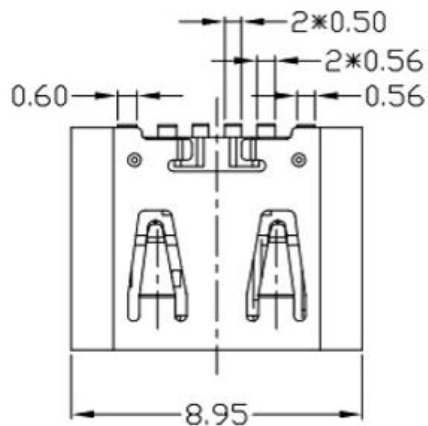

NOTES:

1. ELECTRICAL:

- 1) CURRENT RATING: 5AMP MIN FOR VBUS; VOLTAGE RATING: 20VAC MAX 1.25A FOR GND PIN. 0.25A MIN FOR OTHER.
- 2) INSULATION RESISTANCE: 100MΩMIN;
- 3) CONTACT RESISTANCE: 40mΩMAX;
- 4) WITHSTANDING VOLTAGE: 100V AC;
- 5) OPERATING TEMPERATURE: -25°C TO +85°C.

2 Mechanical:

- 1) INSERTION Force: 5~20N.
- 2) EXTRACTION Force: 8~20N.

3. DIMENSIONS MARKED "▼" TO BE CHECKED BY Q.C & IPQC.

4. PART NO.

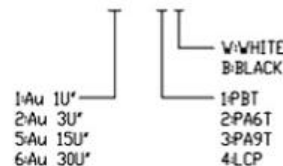

USB TYPE-C 6P RECEPTACLE INTERFACE PIN ASSIGNMENTS

B12	GND
B9	VBUS
B5	CC2
A5	CC1
A9	VBUS
A12	GND
PIN	SIGNAL NAME

⑤	MID PLATE	1	STAINLESS STEEL	Au . PLATING.	T=0.15mm
④	SHELL	1	STAINLESS STEEL	Au . PLATING.	T=0.30mm
③	TERMINAL-B	1	TABLE 2:	TABLE 2:	T=0.12mm
②	TERMINAL-A	1	TABLE 2:	TABLE 2:	T=0.12mm
①	INSULATOR	1	HIGH TEMP	Black	

NO.	PART NAME	QTY	MATERIAL	DESCRIPTION	REMARK
-----	-----------	-----	----------	-------------	--------

UNLESS OTHERWISE, GENERAL TOLERANCE:

- X.xxx ±0.10
- X.xx ±0.20
- X.x ±0.30
- X. ±0.38

ANGULAR:

- X.xx ±1°
- X.x ±3°
- X. ±5°

广东科斯达开关厂

TITLE:	P/N: Detail See PART NO. LIST			
USB connector	MODEL:			
	DRAW NO.:			
THIRD ANGLE PROJECTION	UNIT:	SCALE:	SIZE:	SHEET:
	mm	1:1	A4	1/1

JH2016-080	X2	随工程图上升版本次	2016.06.15	陈少兵	DESIGN	陈少兵	2016.06.15
JH2016-071	X1	新增规格	2016.06.10	陈少兵	CHECK	郑小伟	2016.06.15
20151224001	X	NEW DRAWING	2016.05.05	陈少兵	APPROVAL	吕海涛	2016.06.15
ECN NO.	REV.	DESCRIPTION	DATE	CHANGE			