

RoHS Compliant

NOTES:

1. ELECTRICAL:
  - 1) VOLTAGE CURRENT RATING: 2AMP, 30V AC;
  - 2) INSULATION RESISTANCE: 1000MΩ MIN;
  - 3) CONTACT RESISTANCE: 30mΩ MAX;
  - 4) WITHSTANDING VOLTAGE: 500V AC;
  - 5) OPERATING TEMPERATURE: -55°C TO +85°C.
2. Mechanical:
  - 1) Mating Force: 35N MAX
  - 2) Unmating Force: 10N MIN.
3. NOTE: 1. DIMENSIONS MARKED "▼" TO BE CHECKED BY Q.C & IPQC.
4. PART NO.

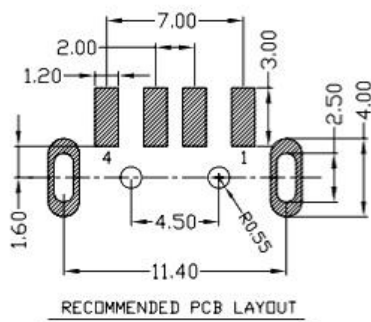
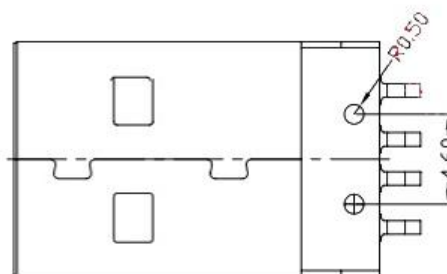
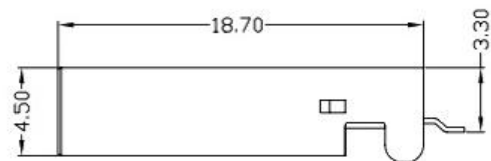
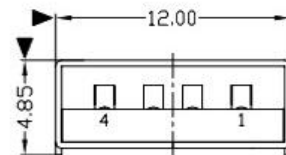
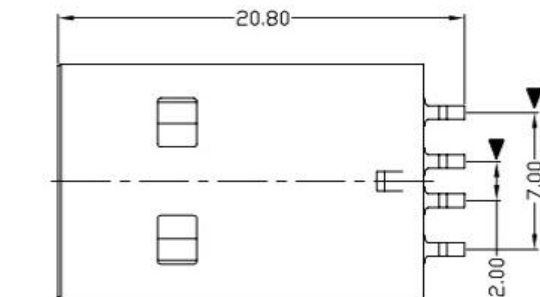

⑤	MID PLATE	1	STAINLESS STEEL	Au . PLATING.	T=0.15mm
④	SHELL	1	STAINLESS STEEL	Au . PLATING.	T=0.30mm
③	TERMINAL-B	1	TABLE 2:	TABLE 2:	T=0.12mm
②	TERMINAL-A	1	TABLE 2:	TABLE 2:	T=0.12mm
①	INSULATOR	1	HIGH TEMP	Black	

NO.	PART NAME	QTY	MATERIAL	DESCRIPTION	REMARK
-----	-----------	-----	----------	-------------	--------

UNLESS OTHERWISE,  
GENERAL TOLERANCE:  
X.xxx ±0.10  
X.xx ±0.20  
X.x ±0.30  
X. ±0.38

ANGULAR:  
X.xx ±1°  
X.x ±3°  
X. ±5°

广东科斯达开关厂

TITLE:	USB connector				P/N: Detail See PART NO. LIST
MODEL:					DRAW NO.:
THIRD ANGLE PROJECTION	UNIT:	SCALE:	SIZE:	SHEET:	
	mm	1:1	A4	1/1	

JH2016-080	X2	随工程图上升版本次	2016.06.15	陈少兵	DESIGN	陈少兵	2016.06.15
JH2016-071	X1	新增规格	2016.06.10	陈少兵	CHECK	郑小伟	2016.06.15
20151224001	X	NEW DRAWING	2016.05.05	陈少兵	APPROVAL	吕海涛	2016.06.15
ECN NO.	REV.	DESCRIPTION	DATE	CHANGE			