

RoHS Compliant

NOTES:

1. ELECTRICAL:

- 1) VOLTAGE CURRENT RATING: 2AMP,30V AC;
- 2) INSULATION RESISTANCE: 1000MΩ MIN;
- 3) CONTACT RESISTANCE: 30mΩ MAX;
- 4) WITHSTANDING VOLTAGE: 500V AC;
- 5) OPERATING TEMPERATURE:-55°C TO +85°C.

2. Mechanical:

- 1) Mating Force: 35N MAX
- 2) Unmating Force: 10N MIN.

3. DIMENSIONS MARKED "▼" TO BE CHECKED BY Q.C & IPQC.

4.PART NO.

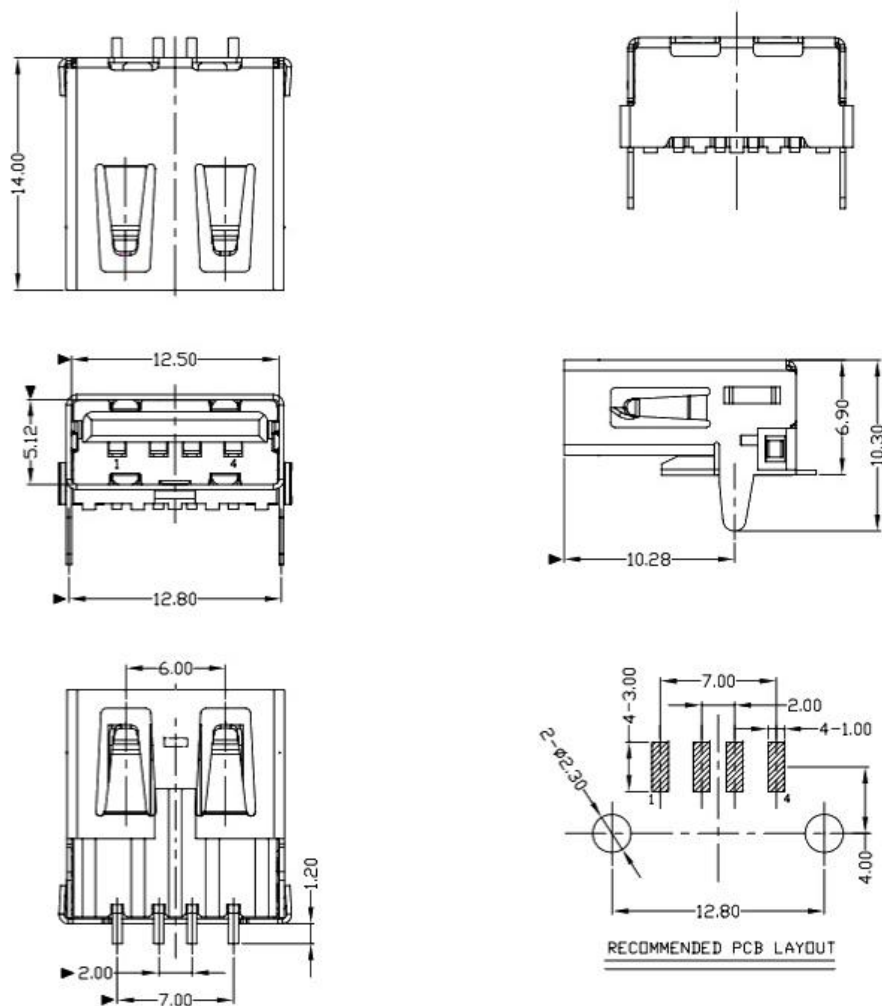

1: Au 1U\*  
6: Au 30U\*

W: WHITE  
B: BLACK

1: PBT  
2: PA6T  
3: PA9T  
4: LCP

⑤	MID PLATE	1	STAINLESS STEEL	Au . PLATING.	T=0.15mm
④	SHELL	1	STAINLESS STEEL	Au . PLATING.	T=0.30mm
③	TERMINAL-B	1	TABLE 2:	TABLE 2:	T=0.12mm
②	TERMINAL-A	1	TABLE 2:	TABLE 2:	T=0.12mm
①	INSULATOR	1	HIGH TEMP	Black	

NO.	PART NAME	QTY	MATERIAL	DESCRIPTION	REMARK
UNLESS OTHERWISE, GENERAL TOLERANCE:					
			X.xxx	±0.10	
			X.xx	±0.20	
			X.x	±0.30	
			X.	±0.38	
ANGULAR:					
			X.xx	±1°	
			X.x	±3°	
			X.	±5°	

广东科斯达开关厂

TITLE: USB connector		P/N: Detail See PART NO. LIST		
THIRD ANGLE PROJECTION		MODEL:		
UNIT: mm		DRAW NO.:		
SCALE: 1:1	SIZE: A4	SHEET: 1/1		

JH2016-080	X2	随工程图上升版本次	2016.06.15	陈少兵	DESIGN	陈少兵	2016.06.15	
JH2016-071	X1	新增规格	2016.06.10	陈少兵	CHECK	郑小伟	2016.06.15	
20151224001	X	NEW DRAWING	2016.05.05	陈少兵	APPROVAL	吕海涛	2016.06.15	
ECN NO.	REV.	DESCRIPTION	DATE	CHANGE				