

RoHS Compliant

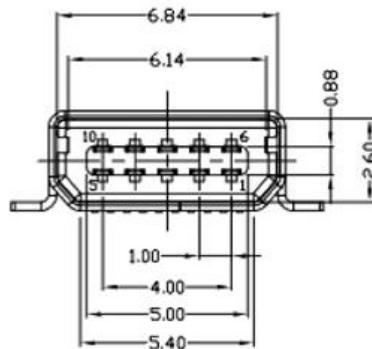
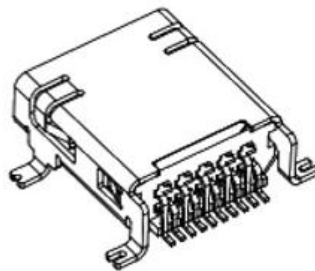
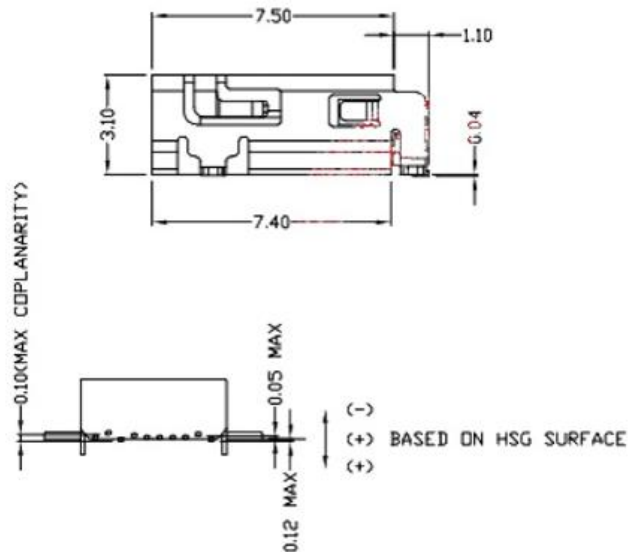

NOTES:

1. ELECTRICAL:

- 1) VOLTAGE CURRENT RATING: 1.0AMP,100V AC;
- 2) INSULATION RESISTANCE: 100MΩ MIN;
- 3) CONTACT RESISTANCE: 50mΩ MAX;
- 4) WITHSTANDING VOLTAGE: 100V AC;
- 5) OPERATING TEMPERATURE:-30°C TO +80°C.

2. Mechanical:

- 1) Mating Force: 35N MAX
- 2) Unmating Force: 7N MIN.

3. DIMENSIONS MARKED "▼" TO BE CHECKED BY Q.C & IPQC.

4.PART NO.

1: Au 1U'
6: Au 30U'

W: WHITE
B: BLACK

1: PBT
2: PA6T
3: PA9T
4: LCP

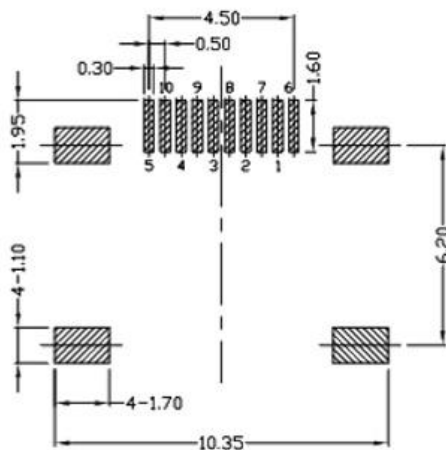
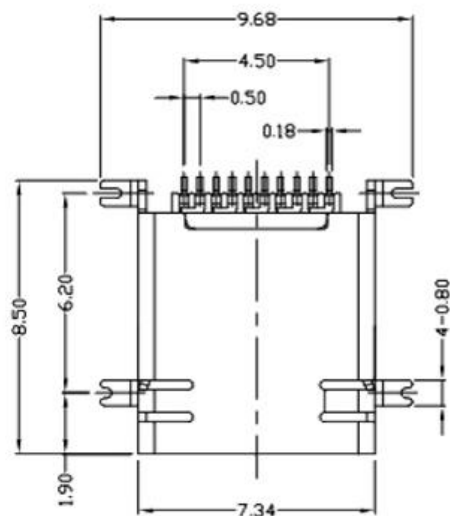

RECOMMENDED PCB LAYOUT(TOP SIDE)

TOLERANCE=±0.05

| | | | | | |
|---|------------|---|-----------------|---------------|----------|
| ⑤ | MID PLATE | 1 | STAINLESS STEEL | Au . PLATING. | T=0.15mm |
| ④ | SHELL | 1 | STAINLESS STEEL | Au . PLATING. | T=0.30mm |
| ③ | TERMINAL-B | 1 | TABLE 2: | TABLE 2: | T=0.12mm |
| ② | TERMINAL-A | 1 | TABLE 2: | TABLE 2: | T=0.12mm |
| ① | INSULATOR | 1 | HIGH TEMP | Black | |

| NO. | PART NAME | QTY | MATERIAL | DESCRIPTION | REMARK |
|-----|-----------|-----|----------|-------------|--------|
|-----|-----------|-----|----------|-------------|--------|

UNLESS OTHERWISE,
GENERAL TOLERANCE:

X.xxx ±0.10
X.xx ±0.20
X.x ±0.30
X. ±0.38

ANGULAR:
X.xx ±1°
X.x ±3°
X. ±5°

广东科斯达开关厂

| | | | | |
|------------------------|-------------------------------|--------|-------|--------|
| TITLE: | P/N: Detail See PART NO. LIST | | | |
| USB connector | MODEL: | | | |
| | DRAW NO.: | | | |
| THIRD ANGLE PROJECTION | UNIT: | SCALE: | SIZE: | SHEET: |
| | mm | 1:1 | A4 | 1/1 |

| | | | | | | | |
|-------------|------|-------------|------------|--------|----------|-----|------------|
| JH2016-080 | X2 | 随工程图上升版本次 | 2016.06.15 | 陈少兵 | DESIGN | 陈少兵 | 2016.06.15 |
| JH2016-071 | X1 | 新增规格 | 2016.06.10 | 陈少兵 | CHECK | 郑小伟 | 2016.06.15 |
| 20151224001 | X | NEW DRAWING | 2016.05.05 | 陈少兵 | APPROVAL | 吕海涛 | 2016.06.15 |
| ECN NO. | REV. | DESCRIPTION | DATE | CHANGE | | | |