

RoHS Compliant

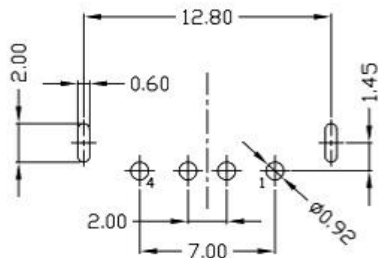
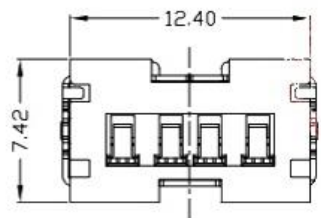
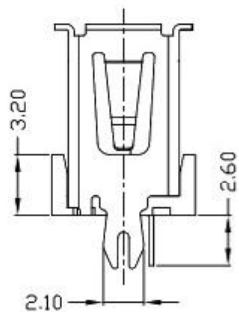
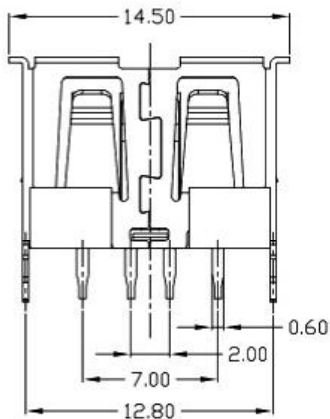
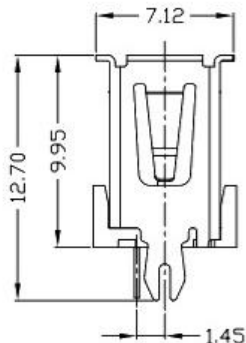
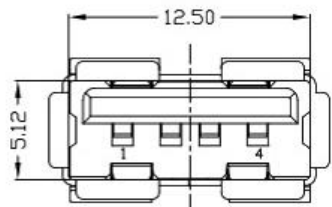

RECOMMENDED PCB LAYOUT

NOTES:

1. ELECTRICAL:
  - 1) VOLTAGE CURRENT RATING: 2AMP, 30V AC;
  - 2) INSULATION RESISTANCE: 1000M $\Omega$ MIN;
  - 3) CONTACT RESISTANCE: 30m $\Omega$ MAX;
  - 4) WITHSTANDING VOLTAGE: 500V AC;
  - 5) OPERATING TEMPERATURE: -55°C TO +85°C.
2. Mechanical:
  - 1) Mating Force: 35N MAX
  - 2) Unmating Force: 10N MIN.
3. DIMENSIONS MARKED \*▼\* TO BE CHECKED BY Q.C & IPQC.
4. PART NO.



| ⑤   | MID PLATE  | 1   | STAINLESS STEEL | Au . PLATING. | T=0.15mm |
|-----|------------|-----|-----------------|---------------|----------|
| ④   | SHELL      | 1   | STAINLESS STEEL | Au . PLATING. | T=0.30mm |
| ③   | TERMINAL-B | 1   | TABLE 2:        | TABLE 2:      | T=0.12mm |
| ②   | TERMINAL-A | 1   | TABLE 2:        | TABLE 2:      | T=0.12mm |
| ①   | INSULATOR  | 1   | HIGH TEMP       | Black         |          |
| NO. | PART NAME  | QTY | MATERIAL        | DESCRIPTION   | REMARK   |

UNLESS OTHERWISE, GENERAL TOLERANCE:

|       |       |
|-------|-------|
| X.xxx | ±0.10 |
| X.xx  | ±0.20 |
| X.x   | ±0.30 |
| X.    | ±0.38 |

ANGULAR:

|      |     |
|------|-----|
| X.xx | ±1° |
| X.x  | ±3° |
| X.   | ±5° |

# 广东科斯达开关厂

|                        |          |                               |  |  |
|------------------------|----------|-------------------------------|--|--|
| TITLE: USB connector   |          | P/N: Detail See PART NO. LIST |  |  |
| THIRD ANGLE PROJECTION |          | MODEL:                        |  |  |
| UNIT: mm               |          | DRAW NO.:                     |  |  |
| SCALE: 1:1             | SIZE: A4 | SHEET: 1/1                    |  |  |

| JH2016-080  | X2   | 随工程图上升版本次   | 2016.06.15 | 陈少兵    | DESIGN   | 陈少兵 | 2016.06.15 |  |
|-------------|------|-------------|------------|--------|----------|-----|------------|--|
| JH2016-071  | X1   | 新增规格        | 2016.06.10 | 陈少兵    | CHECK    | 郑小伟 | 2016.06.15 |  |
| 20151224001 | X    | NEW DRAWING | 2016.05.05 | 陈少兵    | APPROVAL | 吕海涛 | 2016.06.15 |  |
| ECN NO.     | REV. | DESCRIPTION | DATE       | CHANGE |          |     |            |  |