

RoHS Compliant

4.PART NO.

NOTES:

- ELECTRICAL:
 - VOLTAGE CURRENT RATING: 2AMP, 30V AC;
 - INSULATION RESISTANCE: 1000MΩ MIN;
 - CONTACT RESISTANCE: 30mΩ MAX;
 - WITHSTANDING VOLTAGE: 500V AC;
 - OPERATING TEMPERATURE: -40°C TO +85°C.
- Mechanical:
 - Mating Force: 35N MAX
 - Unmating Force: 10N MIN.
- NOTE: 1. DIMENSIONS MARKED "▼" TO BE CHECKED BY Q.C & IPQC.

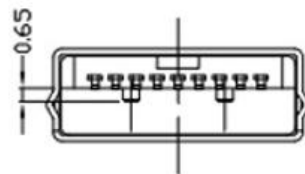
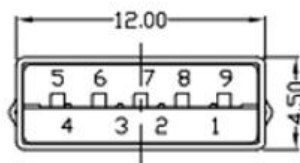
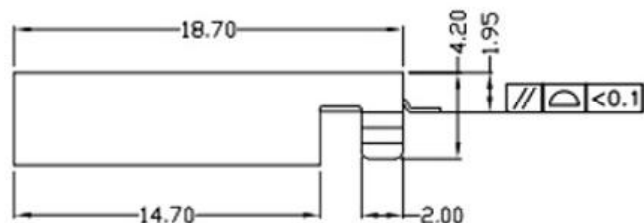
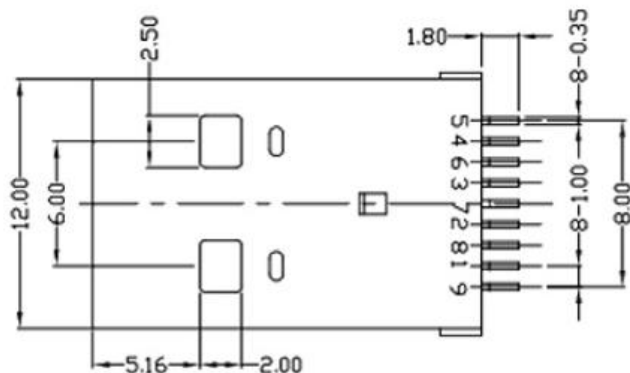
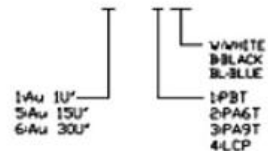

Pin Number	Signal Name	Pin Number	Signal Name
1	V BUS	5	SSRX-
2	D-	6	SSRX+
3	D+	7	GND
4	GND	8	SSTX-
Shell	Shield	9	SSRT+

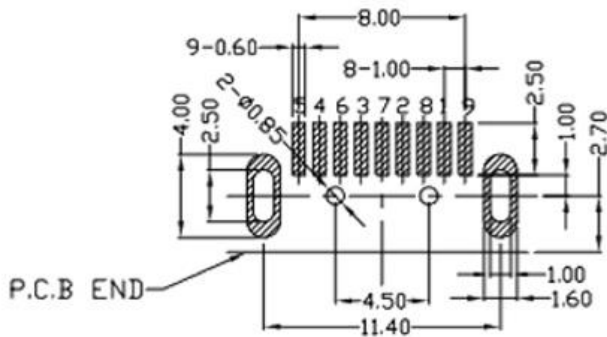
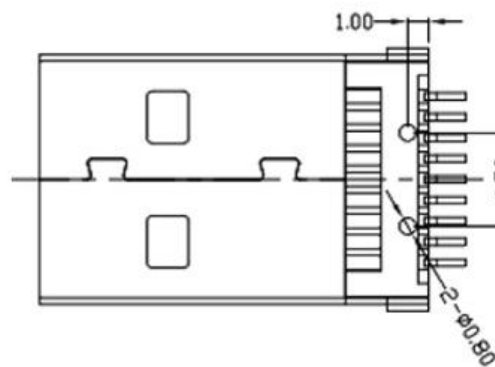

RECOMMENDED PCB LAYOUT

NO.	PART NAME	QTY	MATERIAL	DESCRIPTION	REMARK
⑤	MID PLATE	1	STAINLESS STEEL	Au . PLATING.	T=0.15mm
④	SHELL	1	STAINLESS STEEL	Au . PLATING.	T=0.30mm
③	TERMINAL-B	1	TABLE 2:	TABLE 2:	T=0.12mm
②	TERMINAL-A	1	TABLE 2:	TABLE 2:	T=0.12mm
①	INSULATOR	1	HIGH TEMP	Black	

UNLESS OTHERWISE,
GENERAL TOLERANCE:
X.xxx ±0.10
X.xx ±0.20
X.x ±0.30
X. ±0.38
ANGULAR:
X.xx ±1°
X.x ±3°
X. ±5°

广东科斯达开关厂

TITLE: USB connector	P/N: Detail See PART NO. LIST		
MODEL:			
DRAW NO.:			
THIRD ANGLE PROJECTION	UNIT: mm	SCALE: 1:1	SIZE: A4
		SHEET: 1/1	

ECN NO.	REV.	DESCRIPTION	DATE	CHANGE	APPROVAL	DATE
JH2016-080	X2	随工程图上升版本次	2016.06.15	陈少兵	DESIGN	2016.06.15
JH2016-071	X1	新增规格	2016.06.10	陈少兵	CHECK	2016.06.15
20151224001	X	NEW DRAWING	2016.05.05	陈少兵	APPROVAL	2016.06.15