

RoHS Compliant

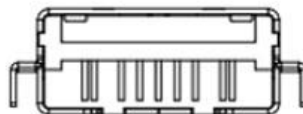
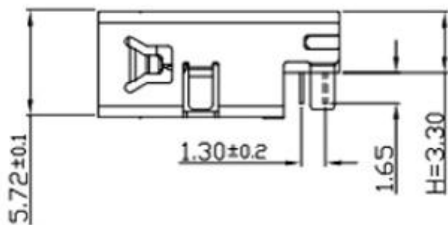
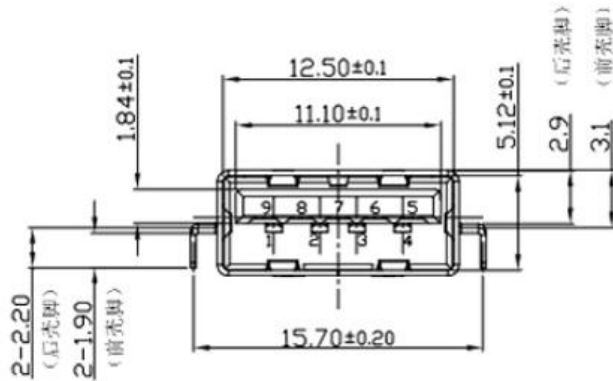
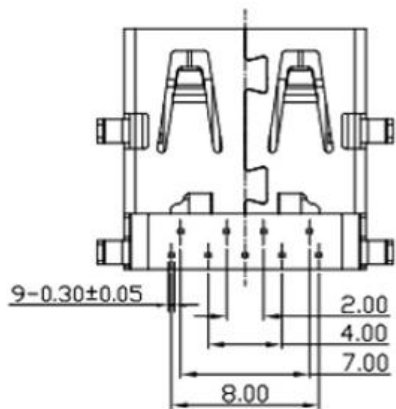
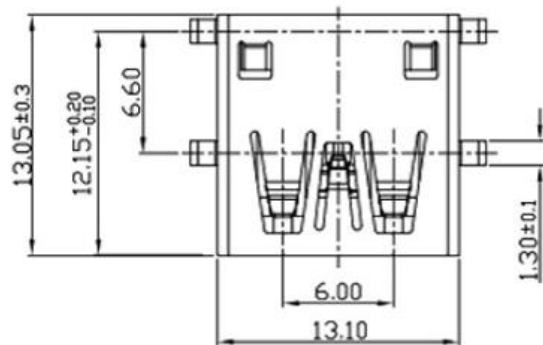

NOTES:

1. ELECTRICAL:

- 1) VOLTAGE CURRENT RATING: 1.5AMP, 30V AC;
- 2) INSULATION RESISTANCE: 1000MΩ MIN;
- 3) CONTACT RESISTANCE: 30mΩ MAX;
- 4) WITHSTANDING VOLTAGE: 500V AC;
- 5) OPERATING TEMPERATURE: -40°C TO +85°C.

2. Mechanical:

- 1) Mating Force: 35N MAX
- 2) Unmating Force: 10N MIN.
- 3) Durability: 5,000 cycles

3. DIMENSIONS MARKED "▼"
TO BE CHECKED BY Q.C & IPQC.

1Au 1U'
5Au 15U'
6Au 30U'

W: WHITE
B: BLACK
BL: BLUE
1PBT
2PA6T
3PA9T
4LCP

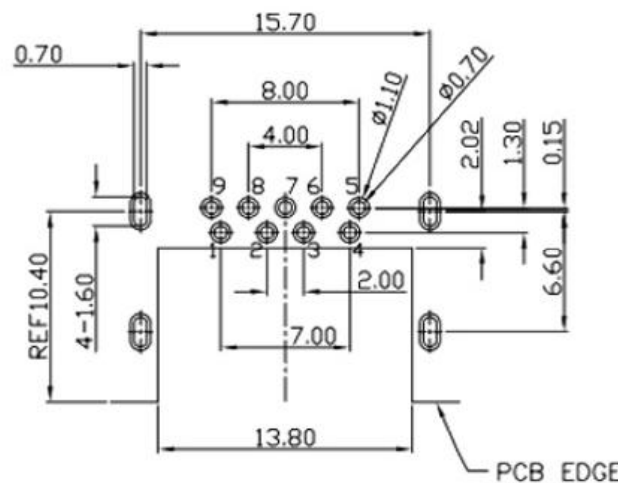

TOLERANCE: ±0.05, THICKNESS: 1.2 mm

RECOMMENDED PCB LAYOUT

Pin #	SIGNAL NAME
1	VBUS
2	D-
3	D+
4	GND
5	StdA_SSRX-
6	StdA_SSRX+
7	GND_DRAIN
8	StdA_SSTX-
9	StdA_SSTX+
Shell	Shield

NO.	PART NAME	QTY	MATERIAL	DESCRIPTION	REMARK
⑤	MID PLATE	1	STAINLESS STEEL	Au . PLATING.	T=0.15mm
④	SHELL	1	STAINLESS STEEL	Au . PLATING.	T=0.30mm
③	TERMINAL-B	1	TABLE 2:	TABLE 2:	T=0.12mm
②	TERMINAL-A	1	TABLE 2:	TABLE 2:	T=0.12mm
①	INSULATOR	1	HIGH TEMP	Black	

NO.	PART NAME	QTY	MATERIAL	DESCRIPTION	REMARK
-----	-----------	-----	----------	-------------	--------

UNLESS OTHERWISE,
GENERAL TOLERANCE:
X.xxx ±0.10
X.xx ±0.20
X.x ±0.30
X. ±0.38
ANGULAR:
X.xx ±1°
X.x ±3°
X. ±5°

广东科斯达开关厂

TITLE: USB connector	P/N: Detail See PART NO. LIST			
MODEL:				
DRAW NO.:				
THIRD ANGLE PROJECTION	UNIT: mm	SCALE: 1:1	SIZE: A4	SHEET: 1/1

ECN NO.	REV.	DESCRIPTION	DATE	CHANGE	APPROVAL	DATE
JH2016-080	X2	随工程图上升版本次	2016.06.15	陈少兵	DESIGN	2016.06.15
JH2016-071	X1	新增规格	2016.06.10	陈少兵	CHECK	2016.06.15
20151224001	X	NEW DRAWING	2016.05.05	陈少兵	CHECK	2016.06.15
					APPROVAL	2016.06.15