

RoHS Compliant

NOTES:

- ELECTRICAL:
  - VOLTAGE CURRENT RATING: 1.5 AMP, 30V AC;
  - INSULATION RESISTANCE: 1000MΩ MIN;
  - CONTACT RESISTANCE: 30mΩ MAX;
  - WITHSTANDING VOLTAGE: 500V AC;
  - OPERATING TEMPERATURE: -40°C TO +85°C.
- Mechanical:
  - Mating Force: 35N MAX
  - Unmating Force: 10N MIN.
- DIMENSIONS MARKED "▼" TO BE CHECKED BY Q.C & IPQC.

4.PART NO.

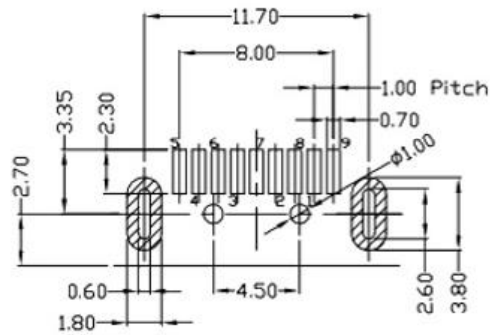
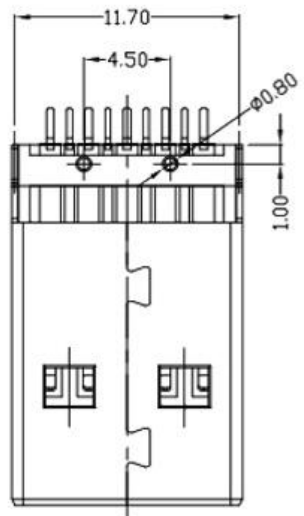
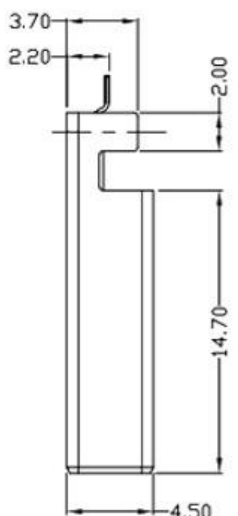
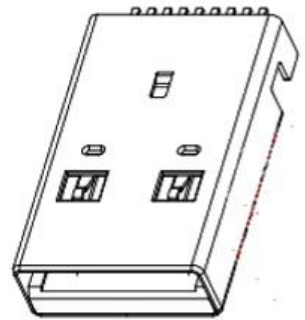
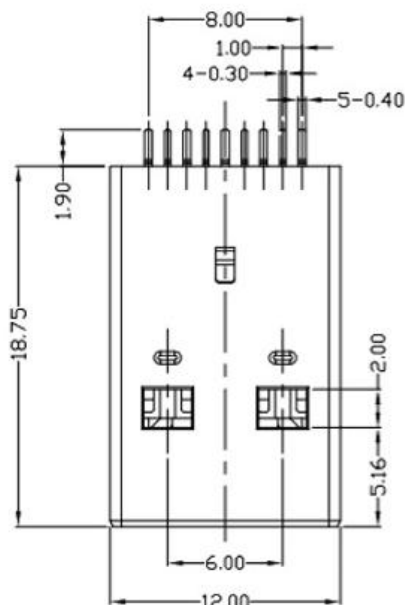

1-Au 1U\*  
5-Au 15U\*  
6-Au 30U\*

W-WHITE  
B-BLACK  
BL-BLUE

1-PBT  
2-PA6T  
3-PA9T  
4-LCP

RECOMMEND PCB LAYOUT  
(TOLERANCE: ±0.05)

⑤	MID PLATE	1	STAINLESS STEEL	Au . PLATING.	T=0.15mm
④	SHELL	1	STAINLESS STEEL	Au . PLATING.	T=0.30mm
③	TERMINAL-B	1	TABLE 2:	TABLE 2:	T=0.12mm
②	TERMINAL-A	1	TABLE 2:	TABLE 2:	T=0.12mm
①	INSULATOR	1	HIGH TEMP	Black	

UNLESS OTHERWISE, GENERAL TOLERANCE:		<h1 style="margin: 0;">广东科斯达开关厂</h1>			
X.xxx	±0.10				
X.xx	±0.20	TITLE: <b>USB connector</b>		P/N: Detail See PART NO. LIST	
X.x	±0.30			MODEL:	
X.	±0.38	THIRD ANGLE PROJECTION		DRAW NO.:	
ANGULAR:				UNIT: mm	SCALE: 1:1
X.xx	±1°				
X.x	±3°				
X.	±5°				

JH2016-080	X2	随工程图上升版本次	2016.06.15	陈少兵	DESIGN	陈少兵	2016.06.15	
JH2016-071	X1	新增规格	2016.06.10	陈少兵	CHECK	郑小伟	2016.06.15	
20151224001	X	NEW DRAWING	2016.05.05	陈少兵	APPROVAL	吕海涛	2016.06.15	
ECN NO.	REV.	DESCRIPTION	DATE	CHANGE				