

RoHS Compliant

NOTES:

- ELECTRICAL:
 - VOLTAGE CURRENT RATING: 1.8AMP, 30V AC;
 - INSULATION RESISTANCE: 1000MΩ MIN;
 - CONTACT RESISTANCE: 30mΩ MAX;
 - WITHSTANDING VOLTAGE: 500V AC;
 - OPERATING TEMPERATURE: -55°C TO +85°C.
- Mechanical:
 - Mating Force: 35N MAX
 - Unmating Force: 10N MIN.
- NOTE: 1. DIMENSIONS MARKED "▼" TO BE CHECKED BY Q.C & IPQC.

4. PART NO.

- W: WHITE
B: BLACK
BL: BLUE
- 1: Au 1U"
5: Au 15u"
6: Au 30U"
- 1: PBT
2: PA6T
3: PA9T
4: LCP
5: PA46

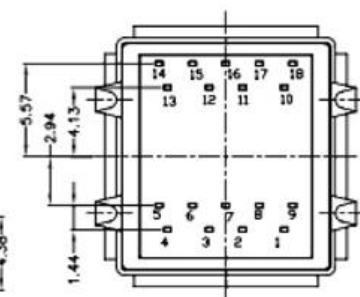
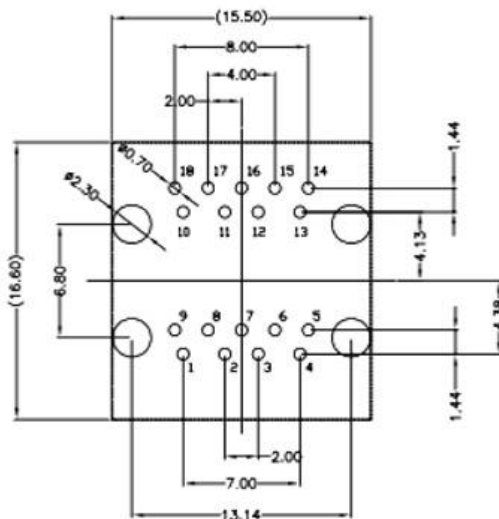
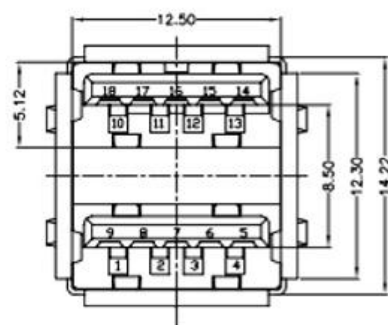
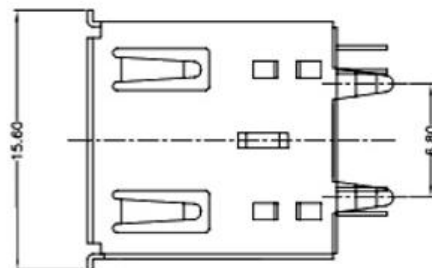
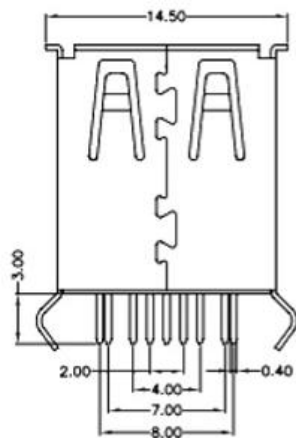
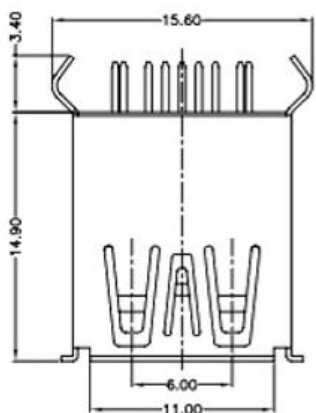

Pin Number	Signal Name	Pin Number	Signal Name
1/10	VBUS	5/14	SSRX-
2/11	D-	6/15	SSRX+
3/12	D+	7/16	GND
4/13	GND	8/17	SSTX-
Shell	Shield	9/18	SSRT+

NO.	PART NAME	QTY	MATERIAL	DESCRIPTION	REMARK
⑤	MID PLATE	1	STAINLESS STEEL	Au . PLATING.	T=0.15mm
④	SHELL	1	STAINLESS STEEL	Au . PLATING.	T=0.30mm
③	TERMINAL-B	1	TABLE 2:	TABLE 2:	T=0.12mm
②	TERMINAL-A	1	TABLE 2:	TABLE 2:	T=0.12mm
①	INSULATOR	1	HIGH TEMP	Black	

RECOMMENDED PCB LAYOUT

UNLESS OTHERWISE, GENERAL TOLERANCE:

X.xxx ±0.10
X.xx ±0.20
X.x ±0.30
X. ±0.38

ANGULAR:
X.xx ±1°
X.x ±3°
X. ±5°

广东科斯达开关厂

TITLE: USB connector

P/N: Detail See PART NO. LIST

MODEL:

DRAW NO.:

THIRD ANGLE PROJECTION

UNIT: mm

SCALE: 1:1

SIZE: A4

SHEET: 1/1

ECN NO.	REV.	DESCRIPTION	DATE	CHANGE	DESIGN	CHECK	APPROVAL
JH2016-080	X2	随工程图上升版本次	2016.06.15	陈少兵	陈少兵		
JH2016-071	X1	新增规格	2016.06.10	陈少兵	陈少兵		
20151224001	X	NEW DRAWING	2016.05.05	陈少兵	陈少兵		
					郑小伟		
					吕海涛		