

RoHS Compliant

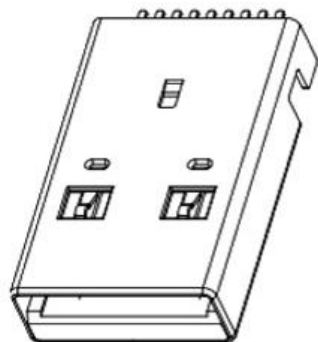
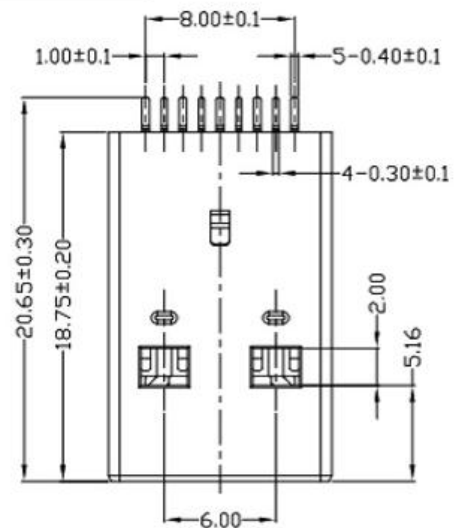

NOTES:

- 1.ELECTRICAL:  
 1) VOLTAGE CURRENT RATING: 1.5AMP, 30V AC;  
 2) INSULATION RESISTANCE: 100MΩ MIN;  
 3) CONTACT RESISTANCE: 30mΩ MAX;  
 4) WITHSTANDING VOLTAGE: 500V AC;  
 5) OPERATING TEMPERATURE: -55°C TO +85°C.
- 2.Mechanical:  
 1) Mating Force: 35N MAX  
 2) Unmating Force: 10N MIN.
- 3.DIMENSIONS MARKED "▼"  
 TO BE CHECKED BY Q.C & IPQC.

4. PART NO.

- 1Au 1U'  
 5Au 15U'  
 6Au 30U'
- W: WHITE  
 B: BLACK  
 BL: BLUE
- 1PBT  
 2PA6T  
 3PA9T  
 4LCP

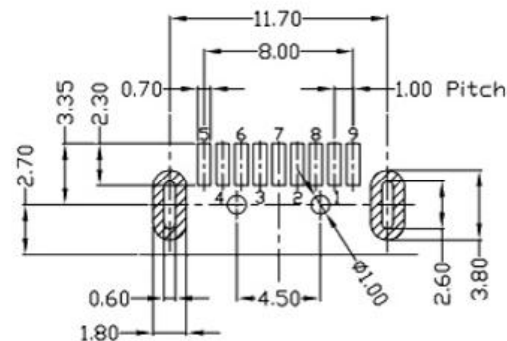
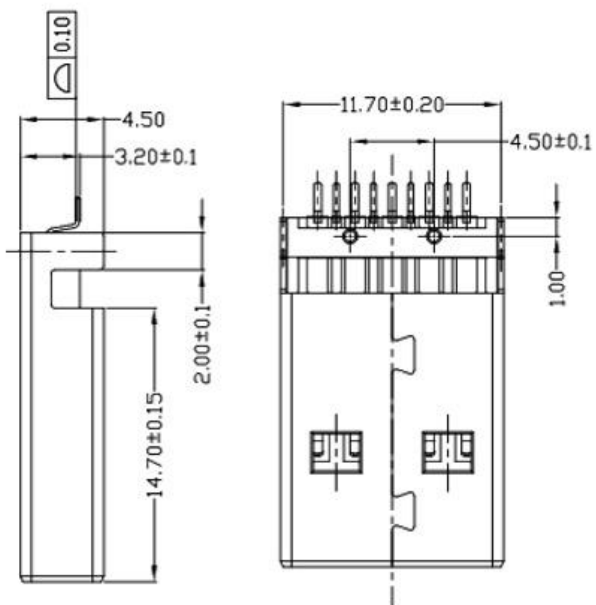
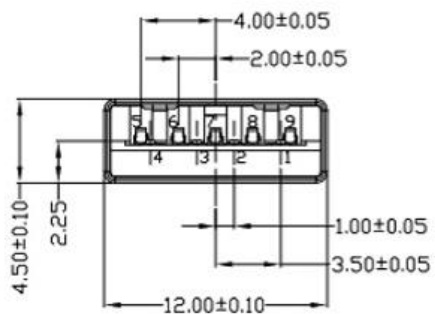

RECOMMENDED P.C.B LAYOUT

⑤	MID PLATE	1	STAINLESS STEEL	Au . PLATING.	T=0.15mm
④	SHELL	1	STAINLESS STEEL	Au . PLATING.	T=0.30mm
③	TERMINAL-B	1	TABLE 2:	TABLE 2:	T=0.12mm
②	TERMINAL-A	1	TABLE 2:	TABLE 2:	T=0.12mm
①	INSULATOR	1	HIGH TEMP	Black	

NO.	PART NAME	QTY	MATERIAL	DESCRIPTION	REMARK
-----	-----------	-----	----------	-------------	--------

UNLESS OTHERWISE,  
 GENERAL TOLERANCE:  
 X.xxx ±0.10  
 X.xx ±0.20  
 X.x ±0.30  
 X. ±0.38

ANGULAR:  
 X.xx ±1°  
 X.x ±3°  
 X. ±5°

广东科斯达开关厂

TITLE: USB connector	P/N: Detail See PART NO. LIST		
MODEL:			
DRAW NO.:			
THIRD ANGLE PROJECTION	UNIT: mm	SCALE: 1:1	SIZE: A4
			SHEET: 1/1

JH2016-080	X2	随工程图上升版本次	2016.06.15	陈少兵	DESIGN	陈少兵	2016.06.15
JH2016-071	X1	新增规格	2016.06.10	陈少兵	CHECK	郑小伟	2016.06.15
20151224001	X	NEW DRAWING	2016.05.05	陈少兵	APPROVAL	吕海涛	2016.06.15
ECN NO.	REV.	DESCRIPTION	DATE	CHANGE			