

RoHS Compliant

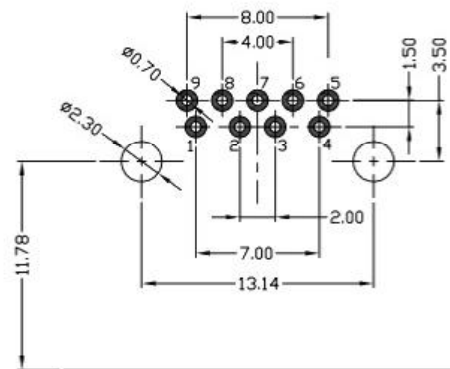
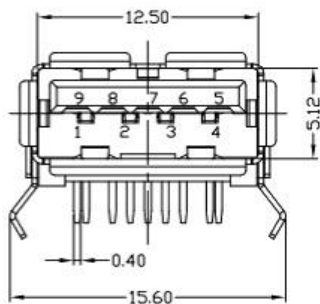
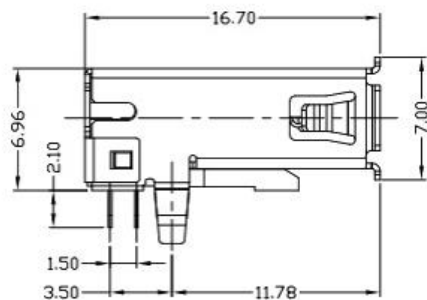
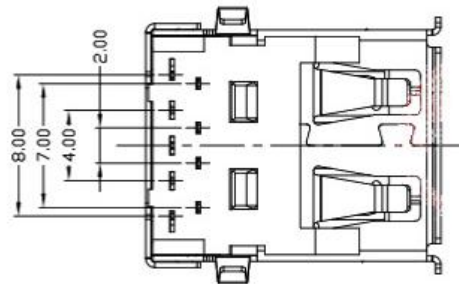
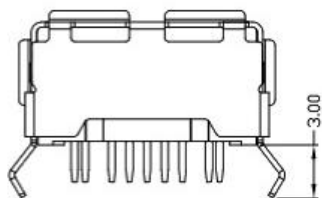
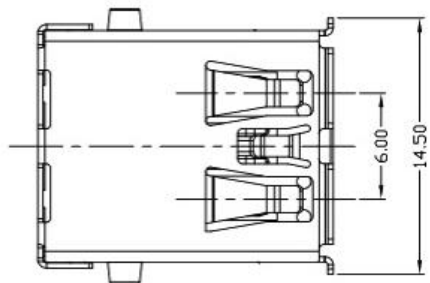

RECOMMENDED PCB LAYOUT

PIN NUMBER	SIGNAL NAME
1	VBUS
2	D-
3	D+
4	GND
5	STDA_SSRX-
6	STDA_SSRX+
7	GND_DRAIN
8	STDA_SSTX-
9	STDA_SSTX+
Shell	Shield

NOTES:

- ELECTRICAL:
 - CURRENT RATING: 1.5AMP;
 - INSULATION RESISTANCE: 100MΩ MIN;
 - CONTACT RESISTANCE: 30mΩ MAX;
 - WITHSTANDING VOLTAGE: 100V AC;
 - OPERATING TEMPERATURE: -40°C ~ +85°C.
- Mechanical:
 - Mating Force: 35N MAX
 - Unmating Force: 10N MIN.
- DIMENSIONS MARKED '▼' TO BE CHECKED BY Q.C & IPQC.

4. PART NO.

1Au 1U"
5Au 15U"
6Au 30U"

W:WHITE
B:BLACK
BL:BLUE
1PBT
2PA6T
3PA9T
4LCP

NO.	PART NAME	QTY	MATERIAL	DESCRIPTION	REMARK
⑤	MID PLATE	1	STAINLESS STEEL	Au . PLATING.	T=0.15mm
④	SHELL	1	STAINLESS STEEL	Au . PLATING.	T=0.30mm
③	TERMINAL-B	1	TABLE 2:	TABLE 2:	T=0.12mm
②	TERMINAL-A	1	TABLE 2:	TABLE 2:	T=0.12mm
①	INSULATOR	1	HIGH TEMP	Black	

UNLESS OTHERWISE,
GENERAL TOLERANCE:

X.xxx ±0.10
X.xx ±0.20
X.x ±0.30
X. ±0.38

ANGULAR:

X.xx ±1°
X.x ±3°
X. ±5°

广东科斯达开关厂

TITLE:
USB connector

P/N: Detail See PART NO. LIST

MODEL:

DRAW NO.:

THIRD ANGLE PROJECTION

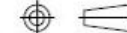

UNIT:

mm

SCALE:

1:1

SIZE:

A4

SHEET:

1/1

JH2016-080	X2	随工程图上升版本次	2016.06.15	陈少兵	DESIGN	陈少兵	2016.06.15
JH2016-071	X1	新增规格	2016.06.10	陈少兵	CHECK	郑小伟	2016.06.15
20151224001	X	NEW DRAWING	2016.05.05	陈少兵	APPROVAL	吕海涛	2016.06.15
ECN NO.	REV.	DESCRIPTION	DATE	CHANGE			