

RoHS Compliant

NOTES:

1. ELECTRICAL:

- 1) CURRENT RATING:1.5AMP;
- 2) INSULATION RESISTANCE: 100MΩ MIN;
- 3) CONTACT RESISTANCE: 30mΩ MAX;
- 4) WITHSTANDING VOLTAGE: 100V AC;
- 5) OPERATING TEMPERATURE:-40°C ~ +85°C.

2. Mechanical:

- 1) Mating Force: 35N MAX
- 2) Unmating Force: 10N MIN.

3. DIMENSIONS MARKED "▼" TO BE CHECKED BY Q.C & IPQC.

4. PART NO.

1-Au 1U'
5-Au 15U'
6-Au 30U'

W:WHITE
B:BLACK
BL:BLUE

1:PBT
2:PA6T
3:PA9T
4:LCP

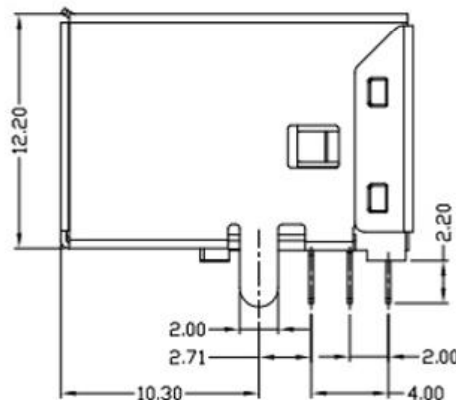
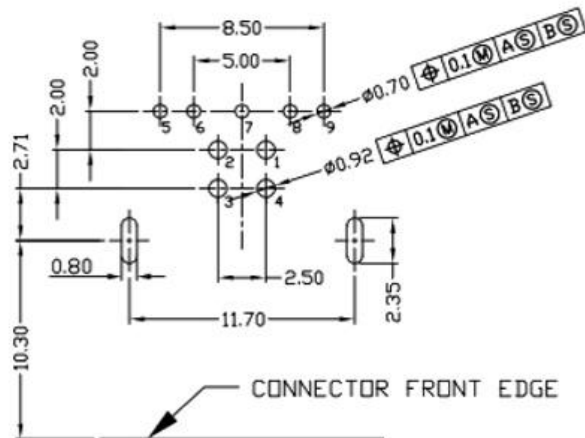
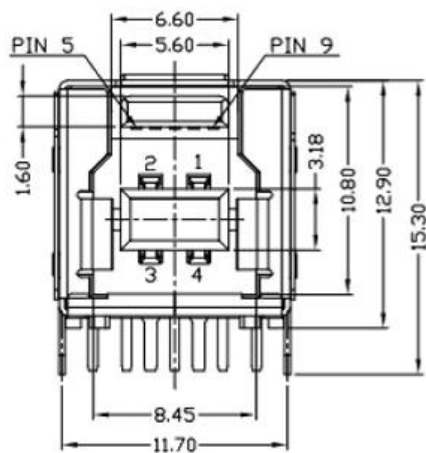
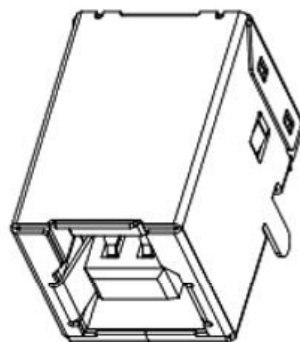
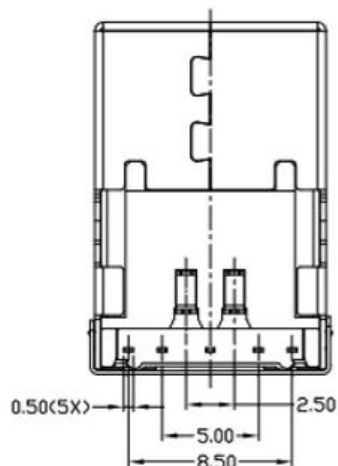
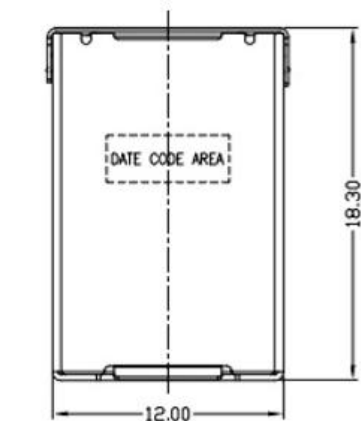

PIN NUMBER	SIGNAL NAME
1	VBUS
2	D-
3	D+
4	GND
5	STDA_SSTX-
6	STDA_SSTX+
7	GND_DRAIN
8	STDA_SSRX-
9	STDA_SSRX+
Shell	Shield

NO.	PART NAME	QTY	MATERIAL	DESCRIPTION	REMARK
⑤	MID PLATE	1	STAINLESS STEEL	Au . PLATING.	T=0.15mm
④	SHELL	1	STAINLESS STEEL	Au . PLATING.	T=0.30mm
③	TERMINAL-B	1	TABLE 2:	TABLE 2:	T=0.12mm
②	TERMINAL-A	1	TABLE 2:	TABLE 2:	T=0.12mm
①	INSULATOR	1	HIGH TEMP	Black	

UNLESS OTHERWISE,
GENERAL TOLERANCE:
X.xxx ±0.10
X.xx ±0.20
X.x ±0.30
X. ±0.38

ANGULAR:
X.xx ±1°
X.x ±3°
X. ±5°

广东科斯达开关厂

TITLE: USB connector	P/N: Detail See PART NO. LIST
THIRD ANGLE PROJECTION	MODEL: DRAW NO.:
UNIT: mm	SCALE: 1:1
	SIZE: A4
	SHEET: 1/1

ECN NO.	REV.	DESCRIPTION	DATE	CHANGE	APPROVAL	DATE
JH2016-080	X2	随工程图上升版本次	2016.06.15	陈少兵	DESIGN	陈少兵 2016.06.15
JH2016-071	X1	新增规格	2016.06.10	陈少兵	CHECK	郑小伟 2016.06.15
20151224001	X	NEW DRAWING	2016.05.05	陈少兵	APPROVAL	吕海涛 2016.06.15