

C		B		A	
ZONE	SYMBOL	REVISION	APPROVAL	DATE	

**RoHS**  
Compliant

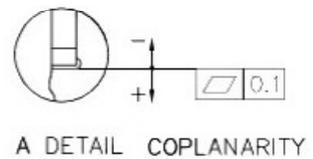
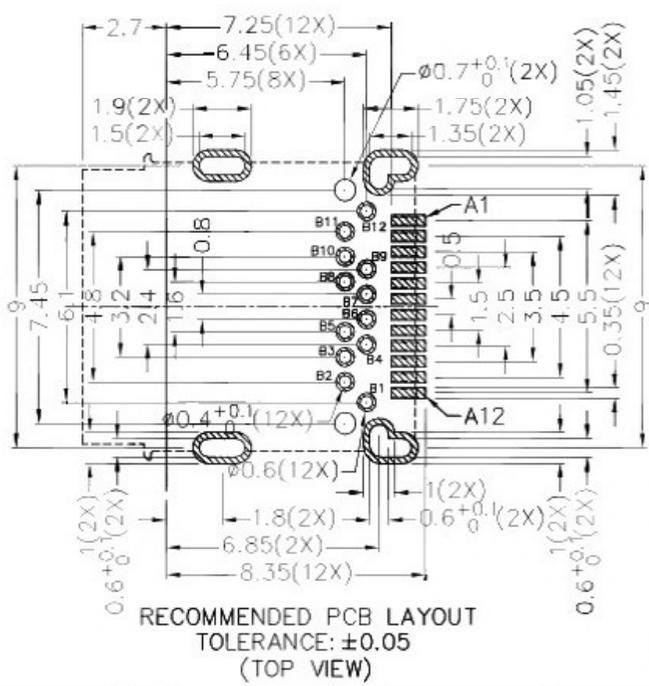
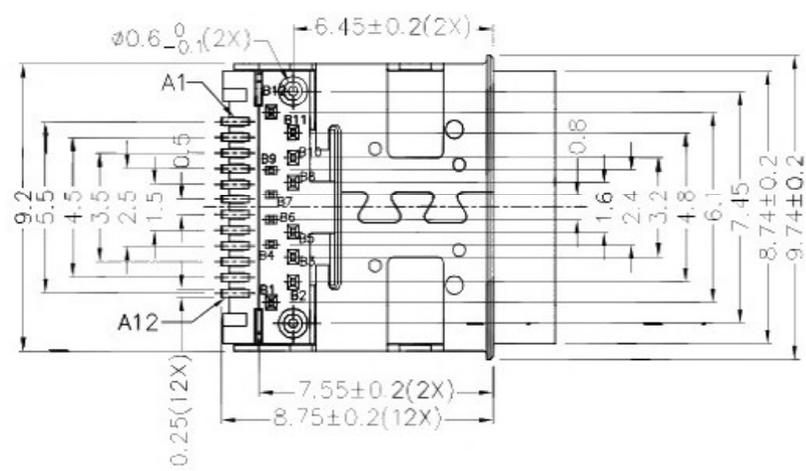
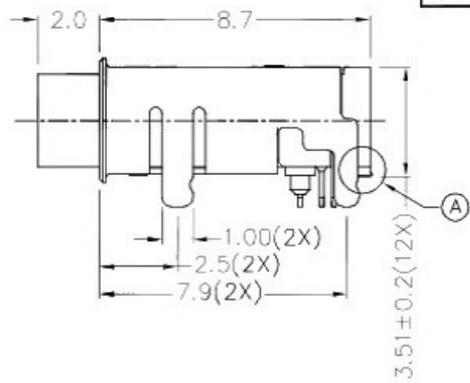
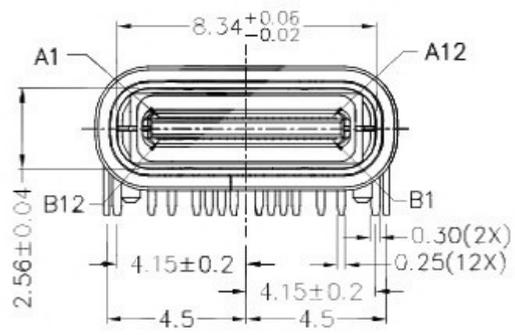
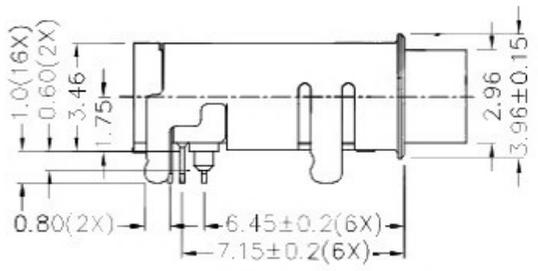

**PIN ASSIGNMENT (FRONT VIEW)**

PIN NO.	A1	A2	A3	A4	A5	A6	A7	A8	A9	A10	A11	A12
	GND	TX1+	TX1-	Vbus	CC1	D+	D-	SBU1	Vbus	RX2-	RX2+	GND
PIN NO.	B12	B11	B10	B9	B8	B7	B6	B5	B4	B3	B2	B1
	GND	RX1+	RX1-	Vbus	SBU2	D-	D+	CC2	Vbus	TX2-	TX2+	GND

RECOMMENDED PCB LAYOUT  
TOLERANCE: ±0.05  
(TOP VIEW)

DESCRIPTION	MATERIAL	PLATING
CONTACT	COPPER ALLOY	NICKEL(Ni) ON ALL AREA, GOLD FLASH ON CONTACT AND SOLDER AREA
SHELL	BRASS	NICKEL(Ni)
COVER SHELL	STAINLESS STEEL	NICKEL(Ni)
INNER GROUND COVER SHELL	STAINLESS STEEL	
MIDDLE PLATE	STAINLESS STEEL	NICKEL(Ni)
INSULATOR	HIGH TEMP. PLASTIC	COLOR: BLACK



**广东科斯达开关厂**

DESIGN	H.L.TAN	DATE	19-8-2019	SCALE	4:1
DRAWING	H.Q.ZHOU	DATE	19-8-2019	MATERIAL	
CHECK	T.Y.LI	DATE	19-8-2019	DWG. NO.	TZ\WPC002D-A/1.0
APPROVAL		DATE		SHEET	1/1

PART NAME	WATERPROOF/DUSTPROOF USB 3.1 TYPE-C CONNECTOR	TOLERANCE UNLESS	0.0±0.2	UNIT:	mm
PART NO.		OTHERWISE SPECIFIED:	0.00±0.1 0.000±0.05		